

QUIETSOURCE™

Installation and Owner's Manual

Liquid-cooled, Prepackaged
Standby Generators

Model Number
004917-4

27 kW NG, 30 kW LP Vapor



This manual should
remain with the unit.

⚠ Not intended for use in life-support applications. ⚠

— ⚠ **DANGER** ⚠ —

DEADLY EXHAUST FUMES. OUTDOOR INSTALLATION ONLY!!

INTRODUCTION

Thank you for purchasing this model of the standby generator set product line by Generac Power Systems.

Every effort was expended to make sure that the information and instructions in this manual are both accurate and current at the time the manual was written. However, the manufacturer reserves the right to change, alter or otherwise improve this product(s) at any time without prior notice.

◆ READ THIS MANUAL THOROUGHLY

If any portion of this manual is not understood, contact the nearest Generac Authorized Service Dealer for starting, operating and servicing procedures.

Throughout this publication, and on tags and decals affixed to the generator, DANGER, WARNING, CAUTION and NOTE blocks are used to alert personnel to special instructions about a particular service or operation that may be hazardous if performed incorrectly or carelessly. Observe them carefully. Their definitions are as follows:



After this heading, read instructions that, if not strictly complied with, will result in personal injury or property damage.



After this heading, read instructions that, if not strictly complied with, may result in personal injury or property damage.



After this heading, read instructions that, if not strictly complied with, could result in damage to equipment and/or property.

NOTE:

After this heading, read explanatory statements that require special emphasis.

These safety warnings cannot eliminate the hazards that they indicate. Common sense and strict compliance with the special instructions while performing the service are essential to preventing accidents.

Four commonly used safety symbols accompany the DANGER, WARNING and CAUTION blocks. The type of information each indicates is as follows:

 This symbol points out important safety information that, if not followed, could endanger personal safety and/or property of others.

 This symbol points out potential explosion hazard.

 This symbol points out potential fire hazard.

 This symbol points out potential electrical shock hazard.

The operator is responsible for proper and safe use of the equipment. Generac strongly recommends that the operator read this Owner's Manual and thoroughly understand all instructions before using this equipment. Generac also strongly recommends instructing other users to properly start and operate the unit. This prepares them if they need to operate the equipment in an emergency.

◆ OPERATION AND MAINTENANCE

It is the operator's responsibility to perform all safety checks, to make sure that all maintenance for safe operation is performed promptly, and to have the equipment checked periodically by a Generac Authorized Service Dealer. Normal maintenance service and replacement of parts are the responsibility of the owner/operator and, as such, are not considered defects in materials or workmanship within the terms of the warranty. Individual operating habits and usage contribute to the need for maintenance service.

Proper maintenance and care of the generator ensures a minimum number of problems and keep operating expenses at a minimum. See the Generac Authorized Service Dealer for service aids and accessories.

Operating instructions presented in this manual assume that the standby electric system has been installed by a Generac Authorized Service Dealer or other competent, qualified contractor. Installation of this equipment is not a "do-it-yourself" project.

◆ HOW TO OBTAIN SERVICE

When the generator requires servicing or repairs, contact a Generac Authorized Service Dealer for assistance. Service technicians are factory-trained and are capable of handling all service needs.

When contacting a Generac Authorized Service Dealer about parts and service, always supply the complete model number of the unit as given on the front cover of this manual or on the DATA CARD affixed to the unit.

AUTHORIZED SERVICE DEALER LOCATION

To locate the nearest GENERAC AUTHORIZED SERVICE DEALER, please call this number:

1-800-333-1322

OR

Locate us on the web at:
www.generac.com

INTRODUCTION.....	IFC	Section 3 — OPERATION	13
SAFETY RULES	2	3.1 Using a Standard “GTS” Transfer Switch.....	13
Section 1 — GENERAL INFORMATION	4	3.2 Control Console Components.....	13
1.1 Generator	4	3.3 Manual Transfer and Startup.....	14
1.2 Transfer Switch	4	3.4 Engine Governor Adjustments	14
1.3 Automatic System Operation	4	3.5 Retransfer and Shutdown.....	15
1.4 Generator AC Connection Systems.....	4	3.6 Automatic Operation	15
1.5 Main Circuit Breaker	4	3.7 Weekly Exercise Cycle.....	15
1.6 Generator Fuel System	5	Section 4 — MAINTENANCE	16
1.7 Engine Protective Devices	5	4.1 Maintenance Performed by Authorized Service Facilities	16
1.8 Unpacking	6	4.2 Cooling System.....	16
1.9 Lifting the Generator	6	4.3 Overload Protection for Engine DC Electrical System	16
1.10 Specifications	7	4.4 Checking Fluid Levels	16
1.11 Fuel Consumption	7	4.5 Maintenance Owner/Operator Can Perform	17
1.12 Reconfiguring the Fuel System	7	4.6 Miscellaneous Maintenance	18
1.13 Torque Specifications	8	4.7 Scheduled Maintenance	20
1.14 Engine Oil Recommendations	8	Section 5 — TROUBLESHOOTING	23
1.15 Coolant Recommendations.....	8	Section 6 — ELECTRICAL DATA	24
1.16 Before Installation	8	Section 7 — EXPLODED VIEWS AND PARTS LISTS	28
Section 2 — INSTALLATION	8	Section 8 — INSTALLATION DIAGRAM	44
2.1 Standby Generator Installation	8	Section 9 — NOTES	45
2.2 Generator Location.....	9	Section 10 — WARRANTY	Back Cover
2.3 Generator Mounting and Support	9		
2.4 Basic Standby Electric System.....	9		
2.5 Emergency Circuit Isolation Method.....	10		
2.6 Total Circuit Isolation Method	10		
2.7 Grounding the Generator	10		
2.8 Generator AC Neutral Connections.....	10		
2.9 Transfer Switch Start Signal Connections	11		
2.10 Battery Installation.....	11		
2.11 Preparation Before Start-Up	12		



⚠ SAVE THESE INSTRUCTIONS – The manufacturer suggests that these rules for safe operation be copied and posted in potential hazard areas. Safety should be stressed to all operators, potential operators, and service and repair technicians for this equipment. **⚠**

⚠ SAVE THESE INSTRUCTIONS – This manual contains important instructions that should be followed during installation and maintenance of the generator and batteries. **⚠**

⚠ WARNING: **⚠**
The engine exhaust from this product contains chemicals known to the state of California to cause cancer, birth defects or other reproductive harm.

⚠ WARNING: **⚠**
This product contains or emits chemicals known to the state of California to cause cancer, birth defects or other reproductive harm.

Study these SAFETY RULES carefully before installing, operating or servicing this equipment. Become familiar with this Owner's Manual and with the unit. The generator can operate safely, efficiently and reliably only if it is properly installed, operated and maintained. Many accidents are caused by failing to follow simple and fundamental rules or precautions.

Generac cannot possibly anticipate every possible circumstance that might involve a hazard. The warnings in this manual, and on tags and decals affixed to the unit are, therefore, not all-inclusive. If using a procedure, work method or operating technique that Generac does not specifically recommend, ensure that it is safe for others. Also make sure the procedure, work method or operating technique chosen does not render the generator unsafe.

⚠ DANGER ⚠

⚠ Despite the safe design of this generator, operating this equipment imprudently, neglecting its maintenance or being careless can cause possible injury or death. Permit only responsible and capable persons to install, operate or maintain this equipment.

⚠ Potentially lethal voltages are generated by these machines. Ensure all steps are taken to render the machine safe before attempting to work on the generator.

⚠ Parts of the generator are rotating and/or hot during operation. Exercise care near running generators.

⚠ GENERAL HAZARDS ⚠

- For safety reasons, Generac recommends that this equipment be installed, serviced and repaired by a Generac Authorized Service Dealer or other competent, qualified electrician or installation technician who is familiar with applicable codes, standards and regulations. The operator also must comply with all such codes, standards and regulations.
- Installation, operation, servicing and repair of this (and related) equipment must always comply with applicable codes, standards, laws and regulations. Adhere strictly to local, state and national electrical and building codes. Comply with regulations the Occupational Safety and Health Administration (OSHA) has established. Also, ensure that the generator is installed, operated and serviced in accordance with the manufacturer's instructions and recommendations. Following installation, do nothing that might render the unit unsafe or in noncompliance with the aforementioned codes, standards, laws and regulations.
- The engine exhaust fumes contain carbon monoxide gas, which can be DEADLY. This dangerous gas, if breathed in sufficient concentrations, can cause unconsciousness or even death. For that reason, adequate ventilation must be provided. Exhaust gases must be piped safely away from any building or enclosure that houses the generator to an area where people, animals, etc., will not be harmed. This exhaust system must be installed properly, in strict compliance with applicable codes and standards.
- Keep hands, feet, clothing, etc., away from drive belts, fans, and other moving or hot parts. Never remove any drive belt or fan guard while the unit is operating.
- Adequate, unobstructed flow of cooling and ventilating air is critical to prevent buildup of explosive gases and to ensure correct generator operation. Do not alter the installation or permit even partial blockage of ventilation provisions, as this can seriously affect safe operation of the generator.
- Keep the area around the generator clean and uncluttered. Remove any materials that could become hazardous.
- When working on this equipment, remain alert at all times. Never work on the equipment when physically or mentally fatigued.

- Inspect the generator regularly, and promptly repair or replace all worn, damaged or defective parts using only factory-approved parts.
- Before performing any maintenance on the generator, disconnect its battery cables to prevent accidental start-up. Disconnect the cable from the battery post indicated by a NEGATIVE, NEG or (-) first. Reconnect that cable last.
- Never use the generator or any of its parts as a step. Stepping on the unit can stress and break parts, and may result in dangerous operating conditions from leaking exhaust gases, fuel leakage, oil leakage, etc.

ELECTRICAL HAZARDS

- All generators covered by this manual produce dangerous electrical voltages and can cause fatal electrical shock. Utility power delivers extremely high and dangerous voltages to the transfer switch as well as the standby generator. Avoid contact with bare wires, terminals, connections, etc., on the generator as well as the transfer switch, if applicable. Ensure all appropriate covers, guards and barriers are in place before operating the generator. If work must be done around an operating unit, stand on an insulated, dry surface to reduce shock hazard.
- Do not handle any kind of electrical device while standing in water, while barefoot, or while hands or feet are wet. **DANGEROUS ELECTRICAL SHOCK MAY RESULT.**
- If people must stand on metal or concrete while installing, operating, servicing, adjusting or repairing this equipment, place insulative mats over a dry wooden platform. Work on the equipment only while standing on such insulative mats.
- The National Electrical Code (NEC), Article 250 requires the frame and external electrically conductive parts of the generator to be connected to an approved earth ground and/or grounding rods. This grounding will help prevent dangerous electrical shock that might be caused by a ground fault condition in the generator set or by static electricity. Never disconnect the ground wire.
- Wire gauge sizes of electrical wiring, cables and cord sets must be adequate to handle the maximum electrical current (ampacity) to which they will be subjected.
- Before installing or servicing this (and related) equipment, make sure that all power voltage supplies are positively turned off at their source. Failure to do so will result in hazardous and possibly fatal electrical shock.
- Connecting this unit to an electrical system normally supplied by an electric utility shall be by means of a transfer switch so as to isolate the generator electric system from the electric utility distribution system when the generator is operating. Failure to isolate the two electric system power sources from each other by such means will result in damage to the generator and may also result in injury or death to utility power workers due to backfeed of electrical energy.

- Generators installed with an automatic transfer switch will crank and start automatically when NORMAL (UTILITY) source voltage is removed or is below an acceptable preset level. To prevent such automatic start-up and possible injury to personnel, disable the generator's automatic start circuit (battery cables, etc.) before working on or around the unit. Then, place a "Do Not Operate" tag on the generator control panel and on the transfer switch.
- In case of accident caused by electric shock, immediately shut down the source of electrical power. If this is not possible, attempt to free the victim from the live conductor. **AVOID DIRECT CONTACT WITH THE VICTIM.** Use a nonconducting implement, such as a dry rope or board, to free the victim from the live conductor. If the victim is unconscious, apply first aid and get immediate medical help.
- Never wear jewelry when working on this equipment. Jewelry can conduct electricity resulting in electric shock, or may get caught in moving components causing injury.

FIRE HAZARDS

- Keep a fire extinguisher near the generator at all times. Do NOT use any carbon tetra-chloride type extinguisher. Its fumes are toxic, and the liquid can deteriorate wiring insulation. Keep the extinguisher properly charged and be familiar with its use. If there are any questions pertaining to fire extinguishers, consult the local fire department.

EXPLOSION HAZARDS

- Properly ventilate any room or building housing the generator to prevent build-up of explosive gas.
- Do not smoke around the generator. Wipe up any fuel or oil spills immediately. Ensure that no combustible materials are left in the generator compartment, or on or near the generator, as FIRE or EXPLOSION may result. Keep the area surrounding the generator clean and free from debris.
- Generac generator sets may operate using one of several types of fuels. All fuel types are potentially FLAMMABLE and/or EXPLOSIVE and should be handled with care. Comply with all laws regulating the storage and handling of fuels. Inspect the unit's fuel system frequently and correct any leaks immediately. Fuel supply lines must be properly installed, purged and leak tested according to applicable fuel-gas codes before placing this equipment into service.
- Diesel fuels are highly FLAMMABLE. Gaseous fluids such as natural gas and liquid propane (LP) gas are extremely EXPLOSIVE. Natural gas is lighter than air, and LP gas is heavier than air; install leak detectors accordingly.

1.1 GENERATOR

This equipment is a liquid-cooled, engine-driven generator set. The generator is designed to supply electrical power that operates critical electrical loads during utility power failure. The unit has been factory-installed in a weather resistant, all aluminum enclosure and is intended for outdoor installation only. Use this generator as a source of electrical power for the operation of 120 and/or 240VAC, single-phase loads.

⚠ WARNING ⚠

⚠ If this generator is used to power electrical load circuits normally powered by a UTILITY power source, it is required by code to install a transfer switch. The transfer switch must effectively isolate the electric system from the utility distribution system when the generator is operating (NEC 701). Failure to isolate an electrical system by such means results in damage to the generator and may also result in injury or even death to utility power workers due to backfeed of electrical energy.

1.2 TRANSFER SWITCH

This generator system may include a matched automatic transfer switch which is intended to be used in conjunction with the Generac generator. It is supplied with a NEMA 3R enclosure. The NEMA 3R enclosure is weather proof and can be used indoors or outdoors. Follow these rules:

- Install the transfer switch on a firm, sturdy supporting structure.
- To prevent switch distortion, level the switch if necessary. This can be done by placing washers between the switch enclosure and the mounting surface.
- Never install the switch where water or any corrosive substance might drip onto the enclosure.
- Protect the switch at all times against excessive moisture, dust, dirt, lint, construction grit and corrosive vapors.

If a transfer switch is not included, one may be purchased separately from a Generac Authorized Dealer.

1.3 AUTOMATIC SYSTEM OPERATION

When this generator, along with a transfer switch, has been installed and interconnected, a circuit board in the generator panel constantly monitors UTILITY power source voltage. Should that voltage drop below a preset value, and remain at such a low state for a preset amount of time, the generator cranks and starts. After the generator starts, the transfer switch transfers load circuits so the generator can power them.

When utility source voltage has been restored, the switch re-transfers back to the UTILITY source voltage and the generator then shuts down.

Please reference the transfer switch manual for specific information.

1.4 GENERATOR AC CONNECTION SYSTEMS

The generator was shipped from the factory with its stator AC output leads connected in a single-phase, three-wire generator AC connection system (Figure 1.1). The stator assembly in this system consists of a pair of stationary windings, with two leads brought out of each winding. Each single winding can supply 120VAC, 60 Hertz. When the two windings are connected in series, a 240VAC, 60 Hertz AC output results. Typically the two HOT leads in the circuit are wires 11 and 44. The NEUTRAL leads are the junction of Wires 22 and 33. The NEUTRAL is not grounded.

Figure 1.1 - Generator AC Connection System

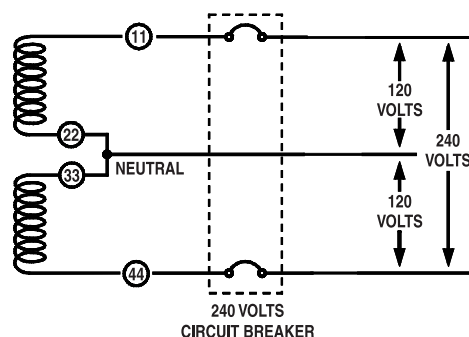

1.5 MAIN CIRCUIT BREAKER

The generator's main circuit breaker is included with the unit as shipped from the factory. The breaker for each unit is described in Figure 1.2.

Figure 1.2 - Main Circuit Breaker

Model	Rating	Phase	Actual Current	C/B Rating*	Circuit Breaker
004917-4	27,000 NG	1	112.5	150	150A QN2
	30,000 LP	1	125.0	150	150A QN2

* Amp Rating of C/B structured under model.

1.6 GENERATOR FUEL SYSTEM

The unit has been factory tested and adjusted using a natural gas fuel system. If propane (LP) gas is necessary. Refer to Section 1.12, Reconfiguring the Fuel System.

Fuel pressure for a natural gas set up should be **five inches to 14 inches of water column (0.18 to 0.5 psi)** at all load ranges.

Fuel pressure for an LP vapor set up should be **11 inches to 14 inches of water column (0.4 to 0.5 psi)** at all load ranges.

NOTE:

A separate gas line and regulator may be needed to assure proper gas pressure to the generator. Improper gas pressure can cause hard starting and affect engine durability.

Gaseous fuels such as natural and LP (propane) gas are highly explosive. Even the slightest spark can ignite such fuels and cause an explosion. No leakage of fuel is permitted. Natural gas, which is lighter than air, tends to collect in high areas. LP gas is heavier than air and tends to settle in low areas.

1.7 ENGINE PROTECTIVE DEVICES

The engine has several safety switches which cause the engine to automatically shut down under the following conditions: low oil pressure, high coolant temperature, engine overspeed, low coolant level or overcrank (Figure 1.3).

Figure 1.3 - Engine Protective Devices

1.7.1 LOW OIL PRESSURE SWITCH

This switch is normally-closed (N.C.), but is held open by engine oil pressure during engine running. Should operating oil pressure drop below about 8-10 psi (55-68 kPa), the switch contacts close, the engine shuts down automatically, and the low oil pressure LED is turned ON (Figure 1.4).

NOTE:

The Low Oil Pressure, High Coolant Temperature and Low Coolant Level are not monitored for the first 10 seconds of engine run time.

Figure 1.4 - Low Oil Pressure Switch

1.7.2 HIGH COOLANT TEMPERATURE SWITCH

This normally open (N.O.) thermostatic switch has sensing tip which is immersed in captive coolant. Should coolant temperature exceed about 230°F (110°C), the switch contacts close. This causes the engine to shut down automatically and turns on the high coolant temperature/low coolant level LED (Figure 1.5).

Figure 1.5- High Coolant Temperature Switch



◆ 1.7.3 LOW COOLANT LEVEL SWITCH

Should engine coolant level drop below the level of the high coolant temperature switch, it is possible for the engine to overheat without automatic shutdown. To prevent such overheating without automatic shut down, the engine has a low coolant level sensor. If the engine coolant drops too low, the engine automatically shuts down and turns on the high coolant temperature/low coolant level LED (Figure 1.6 on page 6).

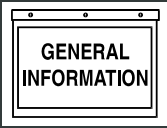

Section 1 – General Information
QUIETSOURCE™ Liquid-cooled 30 kW Generators

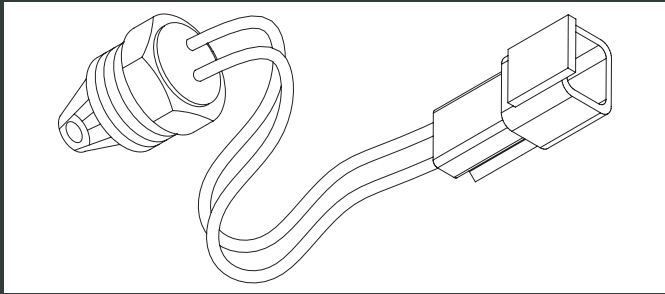

1.10 SPECIFICATIONS

◆ 1.10.1 GENERATOR SPECIFICATIONS

	Single-phase
Model	4917-4
Rated Max. Cont. AC Power Output (kW)	27 (NG), 30 (LP)
Rated voltage (volts)	120/240
No. of Rotor Poles	4
Driven Speed of Rotor	1800
Rotor Excitation System	Direct excited brush type
Type of Stator	4 Wire
Rotor/Stator Insulation	Class F/H

◆ 1.10.2 ENGINE SPECIFICATIONS

Make	Ford
Displacement	3.0 liters
Cylinder Arrangement	V-6
Valve Arrangement	Overhead Valve
Firing Order	1-4-2-5-3-6
Number of Main Bearings.....	4
Compression Ratio.....	9.3 to 1
No. of Teeth on Flywheel	164
Ignition Timing at 1800 rpm.....	30 degrees BTDC
Spark Plug Gap	0.042-0.046 inch
Recommended Spark Plugs	
Motor Craft.....	AG, SF 32PGM
Oil Pressure	40-50 psi
Crankcase Oil Capacity	5.0 U.S. quarts (4.7 liters)
Recommended Engine Oil.....	SAE 5W-20
Type of Cooling System	Pressurized, closed recovery
Cooling Fan	Pusher Type
Cooling System Capacity	3.0 U.S. gallons (11.4 liters)
Recommended Coolant.....	Use a 50-50 mixture of ethylene glycol base and de-ionized water.

1.11 FUEL CONSUMPTION

Natural Gas:

% of Load	25%	50%	75%	100%
m ³ /hr	3.1	5.9	8.5	11.0
ft ³ /hr	110.3	209.0	299.5	387.0

LP Vapor:

% of Load	25%	50%	75%	100%
m ³ /hr	1.3	2.4	3.5	4.5
ft ³ /hr	45.6	86.4	123.8	160.0

NOTE:

Fuel consumption is given at rated maximum continuous power output when using natural gas rated at 1000 Btu per cubic foot. LP gas is rated at 2520 Btu per cubic foot. Actual fuel consumption obtained may vary depending on such variables as applied load, ambient temperature, engine conditions and other environmental factors.

Fuel pressure for a natural gas set up should be **five inches to 14 inches of water column (0.18 to 0.5 psi)** at all load ranges.

Fuel pressure for an LP vapor set up should be **11 inches to 14 inches of water column (0.4 to 0.5 psi)** at all load ranges.

1.12 RECONFIGURING THE FUEL SYSTEM

NOTE:

All models are configured for natural gas from the factory.

To reconfigure the fuel system from NG to LP vapor, follow these steps:

1. Turn the main gas supply off.
2. Remove the carburetor fuel hose from the outlet port (Port 1) of the demand regulator (Figure 1.8).
3. Remove the brass hose fitting from the outlet port (Port 1) of the demand regulator.
4. Remove pipe plug from Port 2.
5. Install brass hose fitting into Port 2.
6. Install pipe plug into Port 1.
7. Connect carburetor gas hose to brass fitting.
8. Tighten all clamps and plugs.
9. Make sure fuel supply is of the proper pressure and type for configuration.
10. Reverse the procedure to convert back to natural gas.

Figure 1.8 — Reconfigure the Fuel System

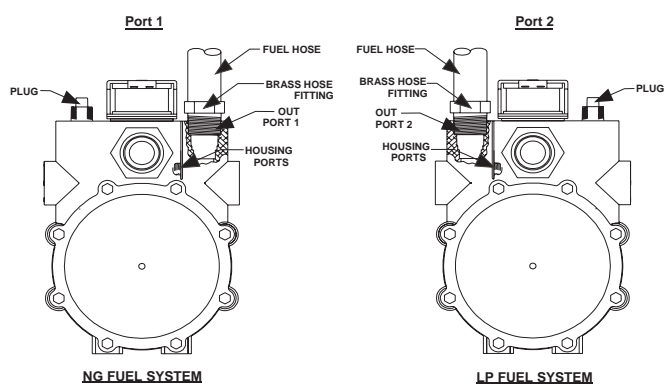

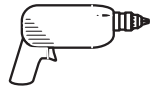

NOTE:

Port 1 is for NG only and Port 2 is for LP vapor only. No provision for dual fuel has been made.



⚠ Serious injury or damage may occur if not configured properly. Please consult an authorized Generac Service Dealer with any questions.

1.13 TORQUE SPECIFICATIONS

- Cylinder Head15 (+ 90° + 90°) ft.lb.
- Intake Manifold13 ft.lb.
- Exhaust Manifold.....13 ft.lb.

1.14 ENGINE OIL RECOMMENDATIONS

The unit has been filled with 5W-20 engine oil at the factory. Use a high-quality detergent oil classified “For Service CC, SD, SE, SF.” Detergent oils keep the engine cleaner and reduce carbon deposits. Use oil having the following SAE viscosity rating, based on the ambient temperature range anticipated before the next oil change:

Temperature	Oil Grade (Recommended)
Above 80° F (27° C)	SAE 5W-20
32° to 80° F (-1° to 27° C)	SAE 5W-20
Below 32° F (0° C)	SAE 5W-20

NOTE:

5W-30 full synthetic oil is highly recommended in any element with temperatures above 90°F or below 30°F.



⚠ Any attempt to crank or start the engine before it has been properly serviced with the recommended oil may result in an engine failure.

1.15 COOLANT RECOMMENDATIONS

Use a mixture of half low silicate ethylene glycol base anti-freeze and half de-ionized water. Cooling system capacity is about 12 U.S. quarts (11.4 liters). Use only de-ionized water and only low silicate anti-freeze. If desired, add a high quality rust inhibitor to the recommended coolant mixture. When adding coolant, always add the recommended 50-50 mixture.



⚠ Do not use any chromate base rust inhibitor with ethylene glycol base anti-freeze or chromi-umhydroxide (“green slime”) forms and will cause overheating. Engines that have been operated with a chromate base rust inhibitor must be chemically cleaned before adding ethylene glycol base anti-freeze. Using any high silicate anti-freeze boosters or additives will also cause overheating. It is also recommend that any soluble oil inhibitor is NOT USED for this equipment.

1.16 BEFORE INSTALLATION

Before installing this equipment, check the ratings of both the generator and the transfer switch. Read “Emergency Isolation Method” and “Total Circuit Isolation Method” in Sections 2.5 and 2.6.

The generator’s rated wattage/amperage capacity must be adequate to handle all electrical loads that the unit will power. The critical (essential) loads may need to be grouped together and wired into a separate “emergency” distribution panel.

This generator can be installed in conjunction with an engineered Generac “GTS” type transfer switch, if necessary.

The standard transfer switch has no sensing or controlling circuit boards. Instead, the generator control console houses a “Printed Circuit Board Assembly”, which controls all phases of operation, including engine start up and load transfer.

2.1 STANDBY GENERATOR INSTALLATION



⚠ Connecting this generator to an electrical system normally supplied by an electric utility shall be by means of a transfer switch, so as to isolate the electric system from the utility distribution system when the generator is operating. Failure to isolate the electric system by these means will result in damage to the generator and may also result in injury or death to utility workers due to backfeed of electrical energy.

⚠ If an open bottom is used, the engine-generator is to be installed over non-combustible materials and should be located such that combustible materials are not capable of accumulating under the generator set.

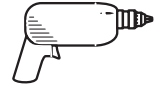

Only qualified, competent installation contractors or electricians thoroughly familiar with applicable codes, standards and regulations should install this standby electric power system. The installation must comply strictly with all codes, standards and regulations pertaining to the installation.

—▲ CAUTION ▲—

▲ After the system has been installed, do nothing that might render the installation in noncompliance with such codes, standards and regulations.

NOTE:

For more information about the installation of a standby system, order *Engine-Generator Standby Electric Power Systems Installer's Guide and Reference Manual* (part #046622) from the Generac Authorized Service Dealer.

◆ 2.1.1 NFPA STANDARDS

The following published standards booklets pertaining to standby electric systems are available from the National Fire Protection Association (NFPA), Batterymarch Park, Quincy, MA 02269:

NOTE:

It is essential to use the latest version of any standard to ensure correct and current information.

- NFPA No. 37, STATIONARY COMBUSTION ENGINES AND GAS TURBINES.
- NFPA No. 76A, ESSENTIAL ELECTRICAL SYSTEMS FOR HEALTH CARE FACILITIES.
- NFPA No. 220, STANDARD TYPES OF BUILDING CONSTRUCTION
- NFPA No. 68, GUIDE FOR EXPLOSION VENTING
- NFPA No. 70, NATIONAL ELECTRICAL CODE.
- NFPA No. 30, FLAMMABLE AND COMBUSTIBLE LIQUIDS CODE.
- NFPA No. 10, INSTALLATION, MAINTENANCE AND USE OF PORTABLE FIRE EXTINGUISHERS.

◆ 2.1.2 OTHER PUBLISHED STANDARDS

In addition to NFPA standards, the following information pertaining to the installation and use of standby electric systems is available:

NOTE:

It is essential to use the latest version of any standard to ensure correct and current information.

- Article X, NATIONAL BUILDING CODE, available from the American Insurance Association, 85 John Street, New York, N.Y. 10038.
- AGRICULTURAL WIRING HANDBOOK, obtainable from the Food and Energy Council, 909 University Avenue, Columbia, MO, 65201.

- ASAE EP-364.2, INSTALLATION AND MAINTENANCE OF FARM STANDBY ELECTRIC POWER, available from the American Society of Agricultural Engineers, 2950 Niles Road, St. Joseph, MI 49085.
- A52.1, AMERICAN NATIONAL STANDARD FOR CHIMNEYS, FIREPLACES AND VENTING SYSTEMS, available from the American National Standard Institute, 1430 Broadway, New York, N.Y. 10018.

2.2 GENERATOR LOCATION

Install the generator set, in its protective enclosure outdoors, where adequate cooling and ventilating air always is available. Consider these factors:

- Install the unit where air inlet and outlet openings will not become obstructed by leaves, grass, snow, etc. If prevailing winds will cause blowing or drifting, consider using a windbreak to protect the unit.
- Install the generator on high ground where water levels will not rise and endanger it.
- This genset must be installed on a level surface. The base frame must be level within 1/2 inch all around.
- Allow sufficient room on all sides of the generator for maintenance and servicing. A good rule is to allow five feet of space on all sides.
- Where strong prevailing winds blow from one direction, face the generator air inlet openings into the prevailing winds.
- Install the generator as close as possible to the transfer switch. This reduces the length of wiring and conduit.
- Install the generator as close as possible to the fuel supply, to reduce the length of piping. **HOWEVER, REMEMBER THAT LAWS OR CODES MAY REGULATE THE DISTANCE.**

2.3 GENERATOR MOUNTING AND SUPPORT

Retain the generator compartment to a concrete slab with 1/4-inch masonry type anchor bolts. Be sure the bolts are long enough to retain the compartment. The slab should be at least six inches thick and should extend beyond the enclosure to a distance of at least three inches on all sides. See Section 6 for generator major dimensions.

2.4 BASIC STANDBY ELECTRIC SYSTEM

Figure 2.1 shows a schematic diagram of a basic standby electric system. Both the UTILITY power supply and the STANDBY (GENERATOR) output are connected to an approved transfer switch. The transfer switch is required by electrical code and serves the following functions:

- Allows the LOAD circuits to be connected to only one power supply at a time.
 - Prevents electrical backfeed between the generator and the UTILITY power circuits.
- Both the STANDBY and the UTILITY power supplies to the transfer switch are protected against overload by a main line circuit breaker.

Figure 2.1 – Basic Standby Electric System

- Ampere rating of the transfer switch must equal the ampere rating of the normal incoming utility service.
- The transfer switch is installed between the utility service entrance and the building distribution panel.

2.7 GROUNDING THE GENERATOR

The National Electrical Code requires the frame and external electrically conductive parts of this equipment to be properly connected to an approved earth ground and/or grounding rods. For that purpose, a GROUND LUG (Figure 2.2) is provided on the generator mounting base. Consult a qualified electrician for grounding requirements in the area. Grounding procedures must meet local regulations.

- ⚠ Do not connect the ground wire to any pipe that carries a flammable or explosive substance – FIRE or an EXPLOSION may result.**

Proper grounding helps protect personnel against electrical shock in the event of a ground fault condition in the generator or in connected electrical devices. In addition, grounding helps dissipate static electricity that often builds up in ungrounded devices.

Figure 2.2 – Generator Grounding Lug (typical)

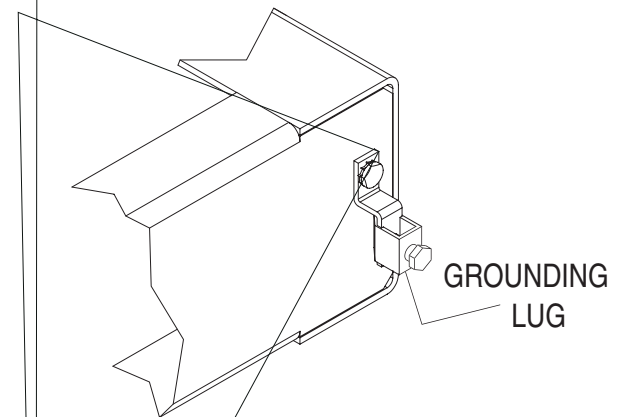

2.8 GENERATOR AC NEUTRAL CONNECTIONS

Generac uses an UNGROUNDED AC neutral. Grounding is recommended only at the main service entrance. If the neutral wire is grounded and one of the phase loads becomes grounded, the excessive current opens the load circuit breaker or collapses the generator field. The actual result depends on the electrical characteristics of the particular installed generator.

2.5 EMERGENCY CIRCUIT ISOLATION METHOD

This prevents overloading the generator by keeping electrical loads below the wattage/ampere capacity of the generator. If the generator is powering only critical loads, within the wattage/ampere capacity, during utility power outages, consider using the emergency circuit isolation method.

Critical electrical loads are grouped together and wired into a separate "Emergency Distribution Panel." Load circuits powered by that panel are within the wattage/ampere capacity of the generator set. When this method is used, it is difficult to overload the generator. The transfer switch must meet the following requirements:

- It must have an ampere rating equal to the total ampere rating of the emergency distribution panel circuit.
- Have it installed between the building's main distribution panel and the emergency distribution panel.

2.6 TOTAL CIRCUIT ISOLATION METHOD

When a generator capable of powering all electrical loads in the circuit is to be installed, use the "Total Circuit Isolation Method." It is possible for the generator to be overloaded when this isolation method is employed. The following apply to the transfer switch in this type of system.

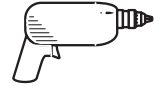

—▲ WARNING ▲—

- ▲ Failure to connect the generator neutral properly will result in unbalanced line-to-neutral voltages. Resulting high voltages will cause equipment damage.

2.9 TRANSFER SWITCH SIGNAL CONNECTIONS

◆ 2.9.1 PRE-PACKAGED ATS

If the generator is to be installed with a pre-packaged (non-control board based) transfer switch, it is necessary to connect the control wires to the generator and set position two of the four-position dip switch to OFF.

Setting switch two to OFF allows the control PCB to perform the ATS control functions.

Control system interconnections consist of N1 and N2, and leads 23 and 194. Control system interconnection leads must be run in a conduit that is separate from the AC power leads. Recommended wire gauge sizes for this wiring depends on the length of the wire, as recommended below:

MAXIMUM WIRE LENGTH	RECOMMENDED WIRE SIZE
460 feet (140m)	No. 18 AWG.
461 to 730 feet (223m)	No. 16 AWG.
731 to 1,160 feet (354m)	No. 14 AWG.
1,161 to 1,850 feet (565m)	No. 12 AWG.

◆ 2.9.2 GTS-TYPE ATS

If the generator is to be installed with an automatic transfer switch, such as an engineered Generac GTS-type switch, it is necessary to connect the two-wire start control system.

Connect the two-wire start signal from the automatic transfer switch to the automatic start connection, which is located in the middle, on the bottom, inside the control panel. Match wires 178 and 183 in the transfer switch to 178 and 183 on the terminal strip in the control panel. The conductors for the two-wire start circuit must be in their own conduit. (See Section 3.1 for further explanation.)

2.10 BATTERY INSTALLATION

—▲ DANGER ▲—

- ▲ Standby generators installed with automatic transfer switches will crank and start automatically when NORMAL (UTILITY) source voltage is removed or is below an acceptable preset level. To prevent such automatic start-up and possible injury to personnel, do not connect battery cables until certain that normal source voltage at the transfer switch is correct and the system is ready to be placed into operation.
- ▲ Storage batteries give off explosive hydrogen gas. This gas can form an explosive mixture around the battery for several hours after charging. The slightest spark can ignite the gas and cause an explosion. Such an explosion can shatter the battery and cause blindness or other injury. Any area that houses a storage battery must be properly ventilated. Do not allow smoking, open flame, sparks or any spark producing tools or equipment near the battery.
- ▲ Battery electrolyte fluid is an extremely caustic sulfuric acid solution that can cause severe burns. Do not permit fluid to contact eyes, skin, clothing, painted surfaces, etc. Wear protective goggles, protective clothing and gloves when handling a battery. If fluid is spilled, flush the affected area immediately with clear water.

—▲ WARNING ▲—

- ▲ Do not dispose of the battery in a fire. The battery is capable of exploding.
- ▲ Do not open or mutilate the battery. Released electrolyte can be toxic and harmful to the skin and eyes.
- ▲ The battery represents a risk of high short circuit current. When working on the battery, always remove watches, rings or other metal objects, and only use tools that have insulated handles.

◆ 2.10.1 VENTED BATTERIES

—▲ CAUTION ▲—

- ▲ The electrolyte is a dilute sulfuric acid that is harmful to the skin and eyes. It is electrically conductive and corrosive. The following procedures are to be observed:
- Wear full eye protection and protective clothing,
 - Where electrolyte contacts the skin, wash it off immediately with water,
 - Where electrolyte contacts the eyes, flush thoroughly and immediately with water and seek medical attention, and

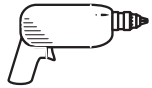

- Spilled electrolyte is to be washed down with an acid-neutralizing agent. A common practice is to use a solution of one pound (500 grams) bicarbonate of soda to one gallon (4 liters) of water. The bicarbonate of soda solution is to be added until the evidence of reaction (foaming) has ceased. The resulting liquid is to be flushed with water and the area dried.

⚠ Lead acid batteries present a risk of fire because they generate hydrogen gas. The following procedure are to be followed:

- DO NOT SMOKE when near batteries,
- DO NOT cause flame or spark in battery area, and
- Discharge static electricity from body before touching batteries by first touching a grounded metal surface.

Servicing of batteries is to be performed or supervised by personnel knowledgeable of batteries and the required precautions. Keep unauthorized personnel away from batteries.

The recommended battery is Group 26, 12VDC, 550 CCA/75 AH minimum. All batteries must be at 100 percent state-of-charge before they are installed on the generator.

When using maintenance-free batteries, it is not necessary to check the specific gravity or electrolyte level. Have these procedures performed at the intervals specified in Section 4, “Maintenance.” A negative ground system is used. Battery connections are shown on the wiring diagrams. Make sure all batteries are correctly connected and terminals are tight. Observe battery polarity when connecting batteries to the generator set.

NOTE:

Damage will result if the battery connections are made in reverse.

2.11 PREPARATION BEFORE START-UP

The instructions in this section assume that the standby generator has been properly installed, serviced, tested, adjusted and otherwise prepared for use by a competent, qualified installation contractor. Be sure to read the “Safety Rules” on Pages 2 and 3, as well as all other safety information in this manual, before attempting to operate this (and related) equipment.

◆ 2.11.1 PRIOR TO INITIAL START-UP



⚠ Prior to initially starting the generator, it must be properly prepared for use. Any attempt to crank or start the engine before it has been properly serviced with the recommended types and quantities of engine fluids (oil, coolant, fuel, etc.) may result in an engine failure.

Before starting the generator for the first time, the installer must complete the following procedures. For follow-up maintenance information and/or service intervals, please refer to Section 4, “Maintenance.”

◆ 2.11.2 TRANSFER SWITCH

If this generator is used to supply power to any electrical system normally powered by an electric utility, the National Electrical Code requires that a transfer switch be installed. The transfer switch prevents electrical backfeed between two different electrical systems (for additional information, see the applicable transfer switch manual for this unit). The transfer switch, as well as the generator and other standby components, must be properly located and mounted in strict compliance with applicable codes, standards and regulations.

◆ 2.11.3 FUEL SYSTEM

Make sure the fuel supply system to the generator (a) delivers the correct fuel at the correct pressure and (b) is properly purged and leak tested according to code. No fuel leakage is permitted. See “Specifications” (Section 1.10) for more information.

◆ 2.11.4 GENERATOR SET LUBRICATION

Check the engine crankcase oil level before operating and add oil to the proper level – the dipstick “FULL” mark. Never operate the engine with the oil level below the dipstick “ADD” mark. See “Specifications” (Section 1.10) and “Engine Oil Recommendations” (Section 1.14).

NOTE:

This engine is shipped from the manufacturer with 5W-20 oil. This oil should be changed after 30 hours of operation.

◆ 2.11.5 ENGINE COOLANT

Have the engine cooling system properly filled with the recommended coolant mixture. Check the system for leaks and other problems. See “Specifications” (Section 1.10) and “Coolant” (Section 1.15).

◆ 2.11.6 BELT TENSION

Check the engine fan belt tension and condition prior to placing the unit into service and at recommended intervals. Belt tension is correct when a force of approximately 22 pounds (10 kg), applied midway between pulleys, deflects the belt about 3/8- to 5/8-inch (10 to 16 mm).

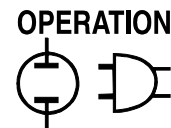

◆ 2.11.7 ELECTRICAL SYSTEM

Make sure the generator is properly connected to an approved earth ground and/or ground rod.

Make sure the generator battery is fully charged, properly installed and interconnected, and ready for use.

Check to ensure that there are no loose electrical connections. Restrain any loose wires to keep them clear of any moving generator set components.

3.1 USING AN ENGINEERED “GTS” TRANSFER SWITCH

When required, the pre-packaged standby generator can be installed with an engineered Generac “GTS” type automatic transfer switch.

In this application, the GTS is responsible for utility sensing, weekly exercising, and load transferring.

Position two of the four-position dip switch is used to turn over this control to the GTS.

Pos2 ON – GTS Application

- The generator’s control board will NOT monitor utility.
- The control board will NOT perform a weekly exercise. (The five red LEDs will not flash in this mode.)
- The control board will NOT activate the transfer output.
- The control board WILL monitor all engine conditions and shut down on all the faults listed in this document.

Pos2 OFF – ATS Application

- The generator’s control board will perform all of the automatic features listed in this document.
- The two-wire start connections should NOT be used.

GTS Mode Operation

When in GTS mode, the generator’s control board will respond as follows based on the AUTO/OFF/MANUAL switch position.

OFF — The generator will not start and run in this position.

MANUAL — The control board will start and run the generator whenever the switch is in the manual position.

AUTO — The control board will monitor the two-wire start circuit. When a two-wire start is issued the control board will immediately start and run the generator. When the two-wire start is removed the control board will immediately stop the generator.

NOTE:

If the generator is installed in conjunction with an engineered GTS type transfer switch, refer to the applicable transfer switch manual for exact operating parameters and timing sequences.

3.2 CONTROL CONSOLE COMPONENTS

The components of a home standby generator control console (Figure 3.1) are as follows:

Figure 3.1 - Home Standby Generator Panel

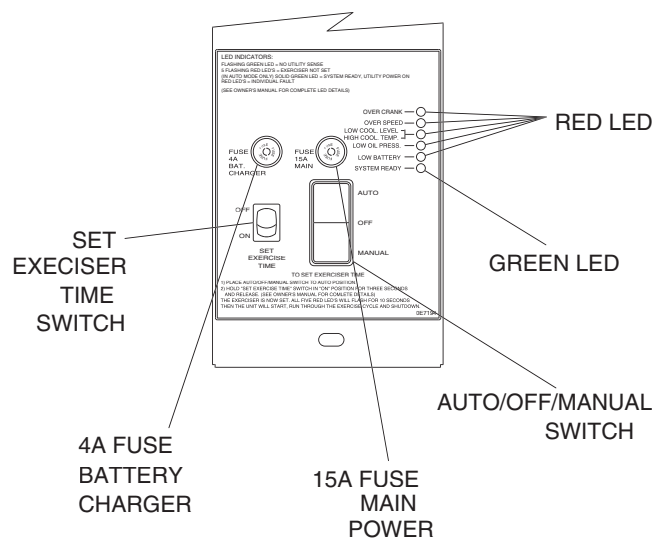

◆ 3.2.1 AUTO/OFF/MANUAL SWITCH

Use this three-position switch as follows:

- Set the switch to AUTO for fully automatic operation. See “Automatic Operation” (Section 3.5).
- Set switch to MANUAL position to crank and start the generator engine.
- Set switch to OFF position to shut down an operating engine. With OFF selected, operation will not be possible.



⚠ With switch set to AUTO, engine can crank and start suddenly without warning. Such automatic start up normally occurs when utility source voltage drops below a pre-set level. To prevent possible injury that might be caused by such sudden starts, set AUTO/OFF/MANUAL switch to OFF before working on or around the unit. Then, place a “DO NOT OPERATE” tag on control console.



3.2.2 FAULT

LED goes ON
faults occur
Low Oil Pressure
Overcrank
Low Battery
Overspeed/RP
High Coolant
Section 1.7
function

3.2.3 15

this fuse pro
circuit agains
melted open b
and startup
replaced, use
fuse. (Type A

3.2.4 4

This fuse pro
cal overload
an identical

**This fuse
power from
the exerc**

3.2.5

This sw
start a
Exercis

3.2

The S
poses
AUTO
utilit
This
auto

The
is f
The
p
is
2 seco
transfer

available with
standard ATS

- 1.
2. Under full load, as much as possible.
3. Apply load. Decrease load until the unit reaches the load point.
4. Under full load, pot until the unit reaches the load point in 50 Hertz application.

Figure 3.2 — Engine



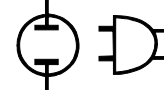

5. Reduce load to 3/4, 1/2, 1/4 and no load. Decrease the stability pot if there is instability at any load point.
6. Adjust differential pot to make the recovery to load changes even faster and minimize load change undershoot and overshoot. If it is set too high it may introduce oscillations at some load. It can be set to zero (full CCW) if a small amount causes oscillations at some load.

3.5 RETRANSFER AND SHUTDOWN

When utility power source voltage has been restored, electrical loads may be transferred back to that source and the generator can be shut down as follows:

- Verify that utility power supply voltage to the transfer switch has been positively turned OFF, using whatever means provided (such as utility main line circuit breaker).
- Set the generator's main circuit breaker to its OFF or OPEN position.
- Let the generator engine run at no-load for a few minutes, to stabilize internal unit temperatures.
- On the generator console, set the AUTO/OFF/MANUAL switch to OFF. Wait for engine to come to a complete stop.
- For transfer to UTILITY position, refer to the Owner's Manual of the particular transfer switch.
- Turn on the utility power supply to the transfer switch, using whatever means provided (such as a utility main line circuit breaker). The utility power source now powers the loads.

3.6 AUTOMATIC OPERATION

To set the system for fully automatic operation, proceed as follows:

- Check that load circuits are connected to the utility power supply.
- Set the AUTO/OFF/MANUAL switch to its AUTO position.
- Set the generator main circuit breaker to its ON or CLOSED position.

3.7 WEEKLY EXERCISE CYCLE

The engine control board will start and run the generator once every seven days for approximately 12 minutes. If utility should fail during this exercise period, the engine control board will transfer the load to the generator output and continue to run until utility returns.

On the day, and at the time of day chosen for the generator to exercise, set the weekly exercise cycle as follows:

1. Place the AUTO/OFF/MANUAL switch in the AUTO position.
2. Press and hold the "Set Exercise" switch for three seconds, then release.

At this time all five red LEDs will flash for approximately 10 seconds, then the engine will start and run for its 12 minute exercise period, then shut down. The generator will now start and run each week at the same time.

If DC power to the control board is lost, the weekly exercise setting will be lost. This is indicated by all five red LEDs continually flashing. In this state the generator will still start and run in manual mode, or automatically start and run if UTILITY is lost while in Auto mode, but it will not perform a weekly exercise cycle.

If a failure occurs while running in this mode, the five red LEDs will stop flashing, the individual fault LED will turn on and the engine will shut down. Once the AUTO/OFF/MANUAL switch has been switch to OFF, the individual fault LED will turn OFF and the five red LEDs will begin flashing to show exercise has still not been set.

Figure 3.2 - "Set Exercise" Switch

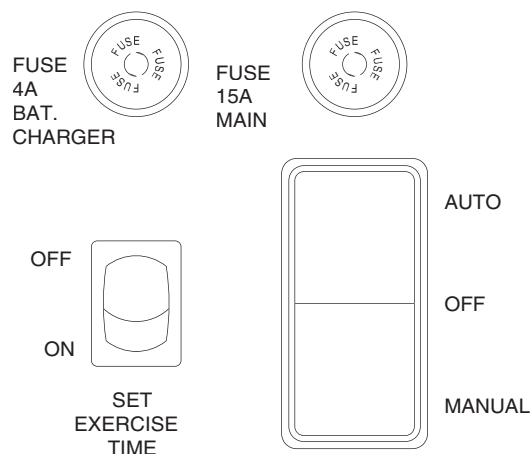

grass, weeds, brush, leaves, etc. must
remain clear of the exhaust. Such materials may
ignite and burn from the heat of the exhaust
system.

Check battery electrolyte fluid at least once weekly.
Fluid should cover separators in all battery cells. If
fluid level is low, add distilled water to cover tops of
separators. **DO NOT USE TAP WATER IN BATTERY.**

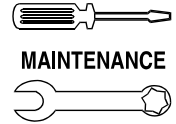

MAINTENANCE

◆ 4.4.3 ENGINE COOLANT

Check coolant level in coolant recovery bottle. See Specifications, Section 1.10.

- Add recommended coolant mixture as necessary.
- Periodically remove radiator pressure cap to make sure the coolant recovery system is functioning properly. Coolant should be at bottom of radiator filler neck. If coolant level is low, inspect gasket in radiator pressure cap. Replace cap, if necessary. To have pressure cap tested, contact an authorized Generac Service Dealer. Inspect cooling system and coolant recovery system for leaks.

4.5 MAINTENANCE OWNER/ OPERATOR CAN PERFORM

◆ 4.5.1 CHECK ENGINE OIL LEVEL

Refer to “Checking Fluid Levels” in Section 4.4.

◆ 4.5.2 CHECK BATTERY

- Check battery fluid level each week as outlined under “Check Fluid Levels”.
- Check battery cables for condition, tightness, corrosion or damage. Clean, tighten or replace as necessary.

◆ 4.5.3 EXERCISE SYSTEM

Start the generator engine at least once every seven days and let it run at least 20 minutes. See Section 3.6, “Weekly Exercise Cycle”.

◆ 4.5.4 INSPECT COOLING SYSTEM

- Inspect engine cooling system at least once each month.
- Check hoses for damage, deterioration, leaks, etc. Correct any discrepancies found.
- Check hose clamps for tightness.

◆ 4.5.5 CHECK ENGINE COOLANT LEVEL

See “Checking Fluid Levels” in Section 4.4.

◆ 4.5.6 PERFORM VISUAL INSPECTION

Complete a thorough visual inspection of the entire engine-generator monthly. Look for obvious damage, loose, missing or corroded nuts, bolts and other fasteners. Look for fuel, oil or coolant leaks.

◆ 4.5.7 INSPECT EXHAUST SYSTEM

Inspect the exhaust system at least once every three months. Check all exhaust system pipes, mufflers, clamps, etc. for condition, tightness, leaks, security, damage.

◆ 4.5.8 CHECK FAN BELT

- Inspect fan belts every three months. Replace any damaged, deteriorated, worn or otherwise defective belt.
- Check fan belt tension. Thumb pressure, exerted midway between pulleys, should deflect about 3/8 to 5/8 inch. Adjust belt tension as required.

◆ 4.5.9 INSPECT ENGINE GOVERNOR

Visually inspect electronic governor.



- ⚠ Do not attempt to adjust the governor. Only qualified service facilities should adjust the governor. Excessively high operating speeds are dangerous and increase the risk of personal injury. Low speeds impose a heavy load on the engine when adequate engine power is not available and may shorten engine life. Correct rated frequency and voltage are supplied only at the proper governed speed. Some connected electrical load devices may be damaged by incorrect frequency and/or voltage. Only qualified service technicians should adjust the governed speed.

◆ 4.5.10 CHANGING ENGINE OIL

Refer to maintenance performed by authorized service facilities for engine oil and filter change frequencies.

Drain the oil while the engine is still warm from running. This means warm up the engine, shut it down and drain immediately as follows:

1. Remove OIL DRAIN HOSE from its retaining clip.
2. Loosen and remove OIL DRAIN HOSE CAP. Drain oil completely into suitable container.
3. When all oil has drained, install and tighten OIL DRAIN HOSE CAP, and re-install into its retaining clip.
4. Turn OIL FILTER (Figure 4.2) counterclockwise and remove. Dispose of old filter.
5. Apply light coating of new engine oil to seal of new oil filter. Install FILTER and tighten by hand only. DO NOT OVERTIGHTEN.
6. Remove OIL FILL CAP. Add recommended oil (see SPECIFICATIONS). DO NOT FILL ABOVE THE DIPSTICK “FULL” MARK. Crankcase oil capacity is 4.0 U.S. quarts (3.8 liters).



- ⚠ After refilling the crankcase with oil, always check oil level on dipstick. NEVER OPERATE ENGINE WITH OIL BELOW THE DIPSTICK “ADD” MARK.

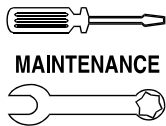

MAINTENANCE

Section 4 – Maintenance

QUIETSOURCE™ Liquid-cooled 30 kW Generators

7. Start engine and check for oil leaks.

Figure 4.2 - Oil Filter

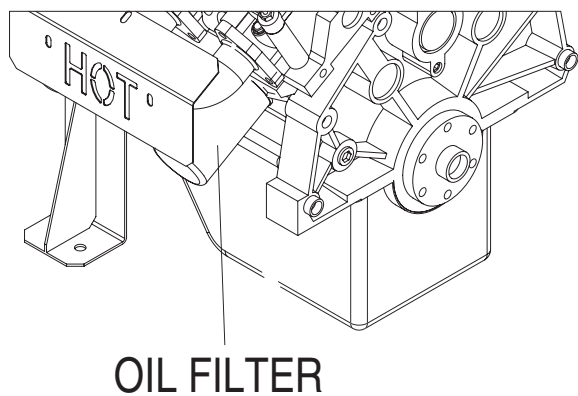

◆ 4.5.11 CHANGING THE ENGINE AIR CLEANER

To replace the engine air cleaner, (part number 059402), remove the air cleaner cover and replace the air filter making sure it is positioned properly before reattaching the cover (Figure 4.3).

Figure 4.3 – Engine Air Cleaner

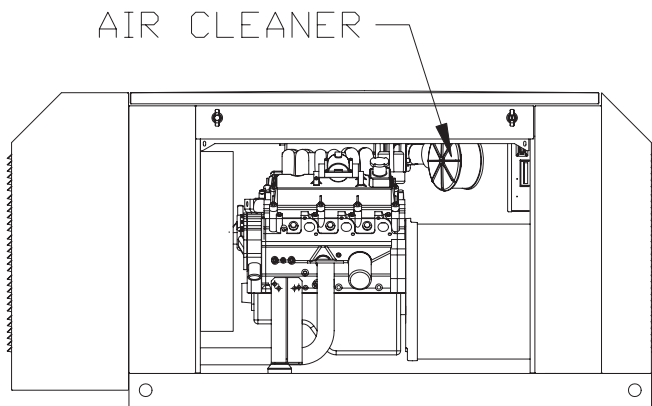

See the “Service Schedule,” Section 6, for air cleaner maintenance.

◆ 4.5.12 SPARK PLUGS

Reset the spark plug gap or replace the spark plugs as necessary. See Section 6.

1. Clean the area around the base of the spark plugs to keep dirt and debris out of the engine. Clean by scraping or washing using a wire brush and commercial solvent. Do not blast the spark plugs to clean.

2. Remove the spark plugs and check the condition. Replace the spark plugs if worn or if reuse is questionable. See the “Service Schedule,” Section 6, for recommended inspection.
3. Check the spark plug gap using a wire feeler gauge. Adjust the gap to 1.06-1.16 mm (0.042-0.046 inch) by carefully bending the ground electrode (Figure 4.4).

Figure 4.4 – Setting the Spark Plug Gap

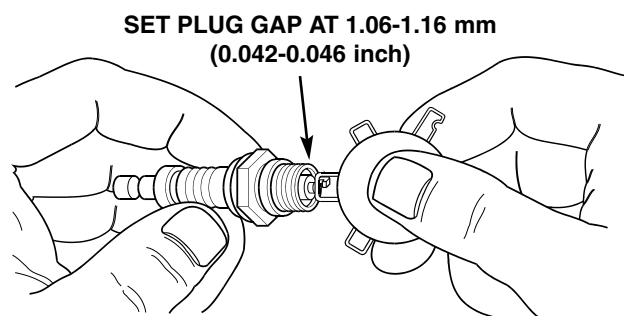

◆ 4.5.13 COOLANT CHANGE

Every year, have Authorized Service Facility drain, flush and refill the cooling system. See SPECIFICATIONS (Section 1.10) for cooling system recommendations.

4.6 MISCELLANEOUS MAINTENANCE

◆ 4.6.1 CLEANING THE GENERATOR

Keep the generator as clean and as dry as possible. Dirt and moisture that accumulates on internal generator windings have an adverse effect on insulation resistance.

Periodically clean generator exterior surfaces. A soft brush may be used to loosen caked on dirt. Use a vacuum system or dry, low pressure air to remove any accumulations of dirt. The generator is housed inside an all-weather enclosure, clean the enclosure with a soft, damp cloth or sponge and water.

Once each year, have the generator cleaned and inspected by an Authorized Service Dealer. That dealer will use dry, low pressure air to clean internal windings. Parts inside the control console should be cleaned and inspected at this time as well.

Finally, have the insulation resistance of stator and rotor windings checked. If insulation resistances are excessively low, the generator may require drying.

4.6.2 BATTERY

All lead-acid storage batteries discharge when not in use. Refer to specific instructions and warnings that accompany the battery. If such information is not available, observe the following precautions when handling a battery:

- DO NOT use jumper cables and a booster battery to crank or start the generator engine.
- DO NOT recharge a weak battery while it is installed in the generator. Remove battery from generator and recharge in a well-ventilated area, away from fuel vapors, sparks, heat or flames.
- Battery electrolyte fluid is an extremely caustic sulfuric solution that can cause severe burns. DO NOT permit fluid to contact eyes, skin, clothing, painted surfaces, wiring insulation, etc. If any battery fluid is spilled, flush the affected area with clear water immediately.
- Always wear safety glasses, rubber apron and gloves when handling a battery.
- Batteries give off explosive hydrogen gas while charging. The gas can form an explosive mixture around the battery for several hours after charging. Any spark, heat or flames can ignite the gas and cause an explosion which can shatter the battery, causing blindness or other serious injury.

4.6.3 BATTERY MAINTENANCE

The battery should be inspected per the "Service Schedule," Section 6. The following procedure should be followed for inspection:

1. Inspect the battery posts and cables for tightness and corrosion. Tighten and clean as necessary.
2. Check the battery fluid level of unsealed batteries and, if necessary, fill with DISTILLED WATER ONLY. DO NOT USE TAP WATER IN BATTERIES.
3. Have the state of charge and condition checked. This should be done with an automotive-type battery hydrometer.

Storage batteries give off explosive hydrogen gas. This gas can form an explosive mixture around the battery for several hours after charging. The slightest spark can ignite the gas and cause an explosion. Such an explosion can shatter the battery and cause blindness or other injury. Any area that houses a storage battery must be properly ventilated. Do not allow smoking, open flame, sparks or any spark producing tools or equipment near the battery.

Battery electrolyte fluid is a sulfuric acid solution that can cause severe burns. Do not permit fluid to contact eyes, skin, clothing, painted surfaces, wiring insulation, etc. If any battery fluid is spilled, flush the affected area immediately with clear water.

Do not use any jumper cables and a booster battery to crank and start the generator. Remove the battery from the generator for recharging.

WARNING

- ⚠ Be sure the AUTO/OFF/MANUAL switch is set to the OFF position before connecting the battery cables. If the switch is set to AUTO or MANUAL, the generator can crank and start as soon as the battery cables are connected.
- ⚠ Be sure the UTILITY power supply is turned off, or sparking may occur at the battery posts as the cables are attached and cause an explosion.

◆ 4.6.4 BATTERY REPLACEMENT

When replacing batteries, use the same number and the type of battery that follows:

NOTE:

The BCI number should be located directly on the battery.

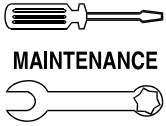

4.7 SCHEDULED MAINTENANCE

Following is a recommended maintenance schedule for Generac small standby and residential generator sets. The established intervals in the schedule are the *maximum* recommended when the unit is used in an average service application. They will need to be decreased (performed more frequently) if the unit is used in a severe application. Use the unit hour meter or calendar time, whichever occurs first, from the previous maintenance interval to determine the next required maintenance interval.

Service Maintenance Interval Information:

The various service maintenance intervals are designated by interval numbers as follows:

- 1 An early inspection of the generator set to ensure it is ready to operate when required and to identify any potential problem areas.

Performed monthly or following each 10 hours of operation of the unit and requires approximately .5 man-hours per unit to complete.

This inspection may be performed by the end user providing the following safety steps are taken to prevent the engine from starting automatically without warning:

To prevent injury, perform the following steps in the order indicated before starting any maintenance:

- Disable the generator set from starting and/or connecting to the load by setting the control panel AUTO-OFF-MANUAL switch to the “OFF” position.
- Remove the control panel fuse.
- Turn off the battery charger.
- Remove the negative battery cable.

The battery charger must be turned off BEFORE removing the battery cable to prevent an over current condition from burning out sensitive control panel components and circuits.

Following all maintenance, reverse these steps to insure the unit is returned to standby setup for normal operation when required.

- 2 A break-in service inspection of the generator set to ensure it is ready to operate and carry the load when required, and to identify any potential problem areas.

*Performed **ONLY ONCE** following the first three months or the first 30 hours of operation after purchase of the unit and requires approximately 2.5 man-hours per unit to complete.*

This inspection contains some maintenance tasks which require special tools, equipment, and/or knowledge to accomplish and should be performed only by an authorized Generac Service Dealer.

- 3 An operational inspection of the generator set to ensure it is ready to operate and carry the load when required, and to identify any potential problem areas.

Performed semi-annually or following each 50 hours of operation of the unit and requires approximately 1.5 man-hours per unit to complete.

This inspection contains some maintenance tasks which require special tools, equipment, and/or knowledge to accomplish and should be performed only by an authorized Generac Service Dealer.

- 4 A mid-level inspection of the generator set to ensure it is ready to operate and carry the load when required, and to identify any potential problem areas.

Performed annually or following each 100 hours of operation of the unit and requires approximately 4.0 man-hours per unit to complete.

This inspection contains some maintenance tasks which require special tools, equipment, and/or knowledge to accomplish and should be performed only by an authorized Generac Service Dealer.

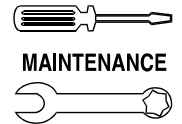

Maintenance Tasks	Level 1	Task Comp. (Date-Initials)	Level 2	Task Comp. (Date-Initials)	Level 3	Task Comp. (Date-Initials)	Level 4	Task Comp. (Date-Initials)
	Recommended to be done monthly		Required to be done 3 months/ Break-in		Required to be done Semi-annually		Required to be done Annually	
1. Disable the unit from operating per the first page warning.	○		○		○		○	
2. Check the engine oil level. Adjust as necessary.	○		○		○		○	
3. Check the engine coolant level. Adjust as necessary.	○		○		○		○	
4. Check the engine coolant thermal protection level. Correct as necessary.							○	
5. Check the natural gas or LP delivery system on gas engine driven units. Tighten connections as necessary.			○		○		○	
6. Check the air inlets and outlets for debris. Clean as necessary.	○		○		○		○	
7. Check the battery electrolyte level if accessible. Adjust as necessary.	○		○		○		○	
8. Check the battery posts, cables, and charger for loose connections, corrosion, and proper operation. Correct as necessary.	○		○		○		○	
9. Check the unit wiring for loose connections, corrosion, and damage. Correct as necessary.							○	
10. Check the engine accessory drive belts for wear, weather cracking, and damage. Replace as necessary.							○	
11. Visually inspect the unit looking for leaks, wear or damage, loose connections or components, and corrosion. Correct as necessary.	○		○		○		○	
12. Test the engine and transfer switch safety devices. Correct and/or adjust as necessary.							○	

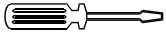

MAINTENANCE

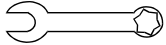

Section 4 – Maintenance

QUIETSOURCE™ Liquid-cooled 30 kW Generators

Maintenance Tasks	Level 1 Recommended to be done monthly	Task Comp. (Date-Initials)	Level 2 Required to be done 3 months/ Break-in	Task Comp. (Date-Initials)	Level 3 Required to be done Semi-annually	Task Comp. (Date-Initials)	Level 4 Required to be done Annually	Task Comp. (Date-Initials)
13. Initiate an automatic start and transfer of the unit to site load and exercise it for at least 1 hour looking for leaks, loose connections or components, and abnormal operating conditions. Correct as necessary.			○		○			
14. Start and exercise the unit at full rated load (use a load bank if the site load is not enough) for at least 2 hours looking for leaks, loose connections or components, and abnormal operating conditions. Correct as necessary.							○	
15. Change the engine oil.			○				○	
16. Replace the engine oil filter(s).			○				○	
17. Replace the engine air filter(s).							○	
18. Replace the engine fuel filter(s) on diesel engine driven units and re-prime the fuel system.			○				○	
19. Check the engine spark plugs on gas engine driven units. Clean and re-gap or replace as necessary.			○				○	
20. Perform a 5 minute no-load operational run of the unit looking for any post service problems.			○				○	
21. Return the unit to standby setup for operation when required.	○		○		○		○	



TROUBLESHOOTING POINTS

PROBLEM	CAUSE	CORRECTION
Engine won't crank.	<ol style="list-style-type: none"> 15 amp fuse blown. Loose or corroded or defective battery cables. Defective starter contactor. Defective starter motor. Dead or Defective Battery. 4 amp fuse blown. 	<ol style="list-style-type: none"> Replace fuse. Tighten, clean or replace battery cables as necessary. Replace contactor. Replace starter motor. Remove, change or replace battery. Replace fuse.
Engine cranks, but won't start	<ol style="list-style-type: none"> Out of fuel. Fuel solenoid (FS) is defective Open Wire #14 from Engine Control circuit board. Spark plugs defective. 	<ol style="list-style-type: none"> Replenish fuel. Replace solenoid. Reconnect wire. Clean, regap or replace plugs.
Engine starts hard, runs rough.	<ol style="list-style-type: none"> Flame arrestor (air cleaner) plugged or damaged. Plugged fuel line. Defective spark plugs. 	<ol style="list-style-type: none"> Clean or replace as needed. Unclog fuel line. Clean, regap or replace plugs.
Engine starts, then shuts down.	<ol style="list-style-type: none"> Engine oil level is low. Engine is overheated. Defective Low Oil Pressure Switch Defective Coolant Temperature Switch Defective Control Module circuit board. Coolant Level is Low. Defective Low Coolant Level Switch 	<ol style="list-style-type: none"> Check oil and add oil as needed. Check cooling system for leaks. Replace switch. Replace switch. Replace board. Repair leak - Add coolant. Replace Switch.
AUTO/OFF/MANUAL Switch at, OFF engine continues to run	<ol style="list-style-type: none"> Defective AUTO/OFF/MANUAL switch Open/disconnected wire #15A between AUTO/OFF/MANUAL switch and Control Module circuit board. Defective Control Module circuit board 	<ol style="list-style-type: none"> Replace switch. Reconnect/close wire. Replace board.
No AC output from generator.	<ol style="list-style-type: none"> Check main line circuit breaker. Check circuit breaker & fuses. Transfer switch set to NORMAL position Generator internal failure. Thermal circuit breaker open. 	<ol style="list-style-type: none"> Reset to ON or CLOSED. Reset and replace, if necessary. Set to GENERATOR position. Contact an Authorized Generac facility. Auto-reset - Wait five minutes and attempt restart.

NOTE:
ALL WIRES ARE 18 AWG 300
VOLT UNLISTED UNLESS
OTHERWISE NOTED AS SHOWN:

SIZE (AWG)

16

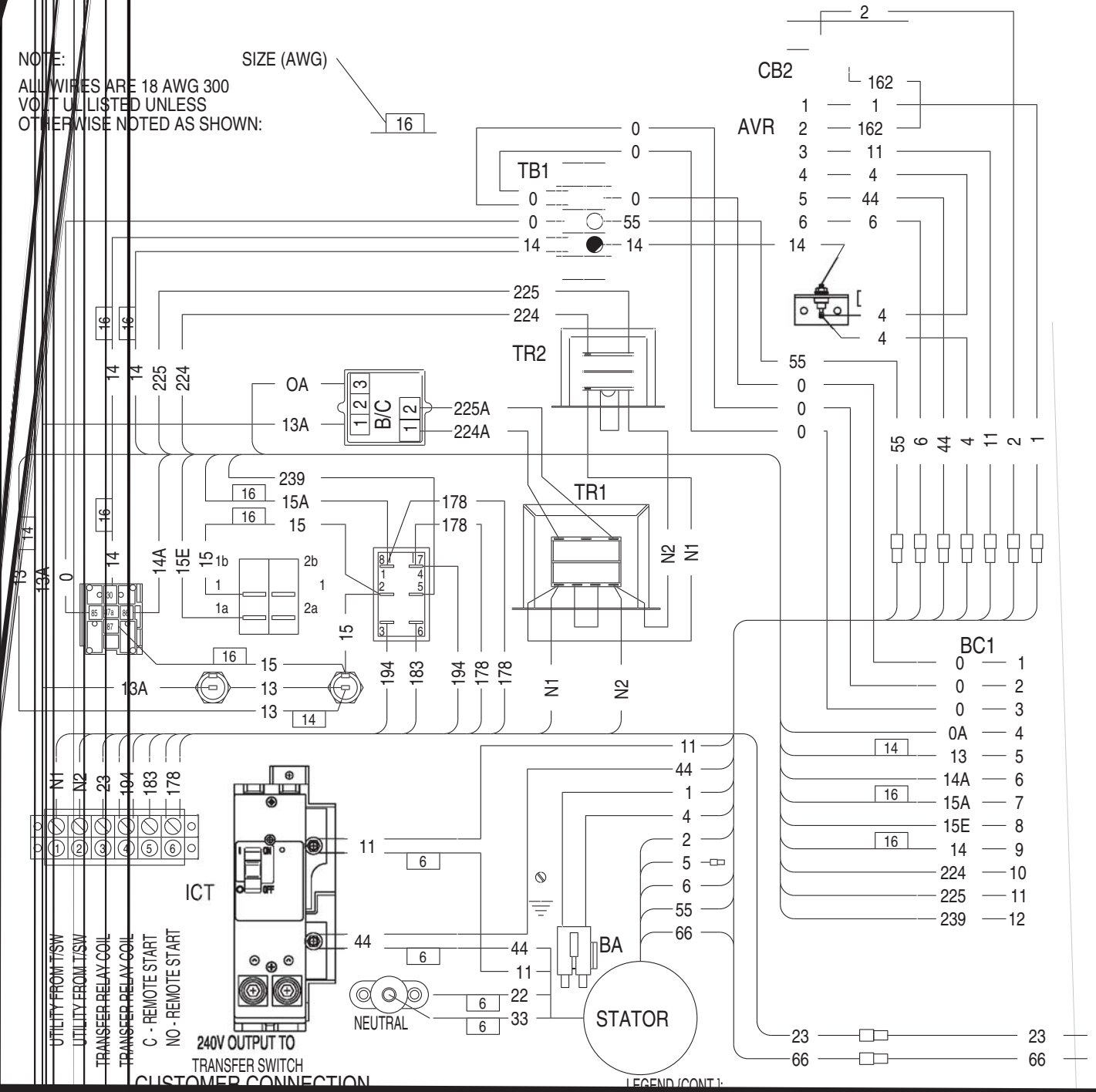

LEGEND (CONT.)

LEGEND:

- AUTOMATIC VOLTAGE REGULATOR
- BRUSH ASSEMBLY (GENERATOR)
- BATTERY CHARGER
- BULKHEAD CONNECTOR 1 (ENGINE)
- CIRCUIT BREAKER (OUTPUT)
- CIRCUIT BREAKER (EXCITATION)
- DIODE [FIELD BOOST]
- FUSE, BAT. POWER (15A AGC TYPE)

- ICT - INTERCONNECT. TERMINAL BLOCK
- NB - NEUTRAL BLOCK
- RL1 - RELAY 1
- SW1 - AUTO/OFF/MANUAL SWITCH
- SW2 - SET EXERCISER SWITCH
- TB1 - TERMINAL BLOCK 1
- TR1 - TRANSFORMER 1 (56 VA 240/16 VAC)
- TR2 - TRANSFORMER 2 (6 VA 240/16 VAC)

Section 6 - Electrical Data

QUIETSOURCE™ Liquid-cooled 30 kW Generators
Wiring Diagram – Engine – Drawing No. 0E6199-F

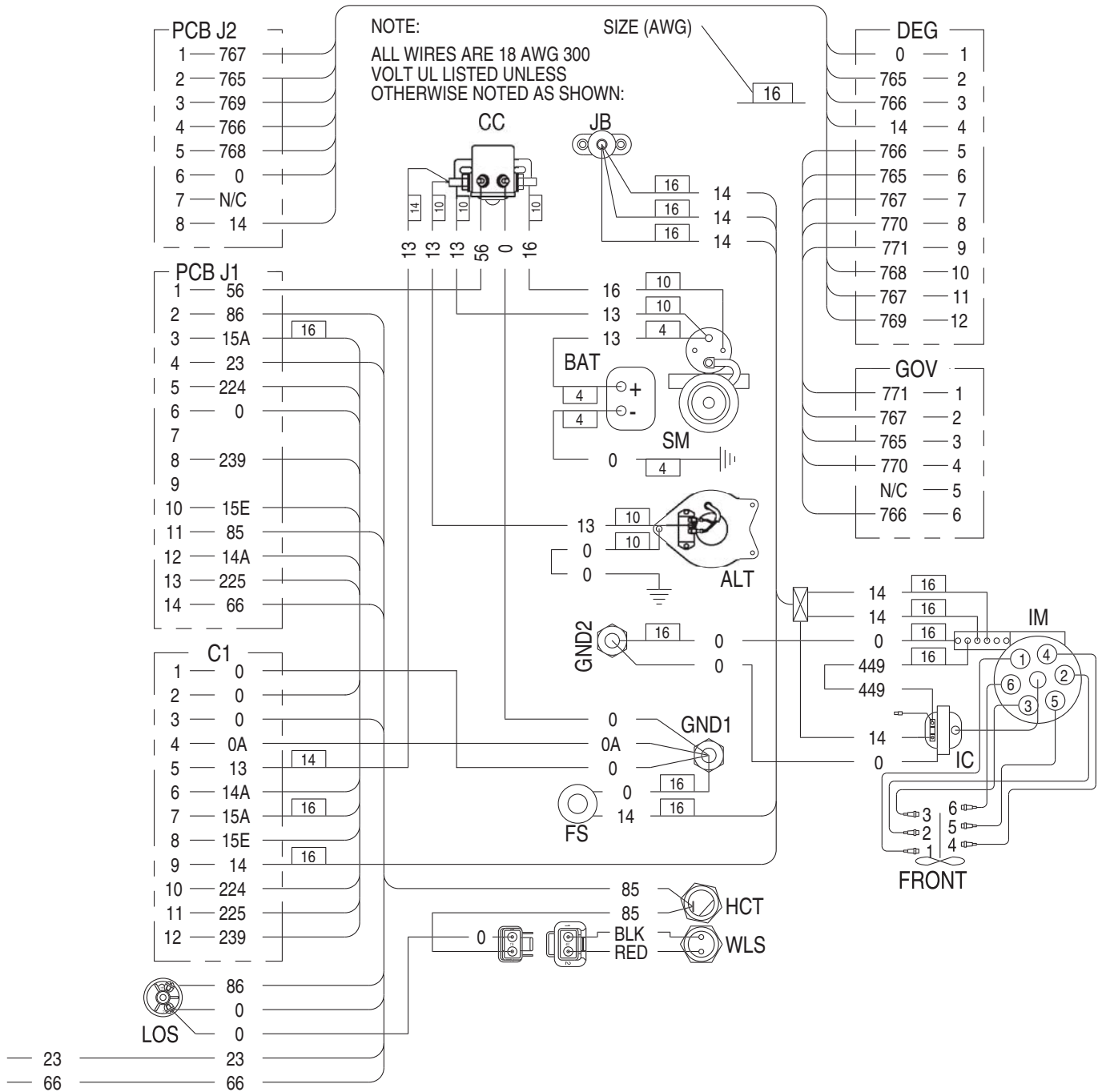
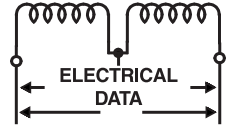

- LEGEND:
- ALT - D.C. CHARGE ALTERNATOR
 - BAT - 12VDC BATTERY
 - C1 - CONNECTOR 1 (ENGINE)
 - CC - STARTER CONTACTOR
 - DEG - DRIVER ELEC. GOVERNOR
 - FS - FUEL SOLENOID
 - GND1- GROUND (SENSING/LOW AMP)
 - GND2- GROUND (POWER/HIGH AMP)
 - GOV - ELEC. GOVERNOR ACTUATOR

- LEGEND (CONT.):
- HCT - HIGH COOLANT TEMP SWITCH
 - IC - IGNITION COIL
 - IM - IGNITION MODULE (ON DISTRIBUTOR)
 - J-1- JUNCTION 1 (ON PCB)
 - J-2- JUNCTION 2 (ON PCB)
 - JB - JUNCTION BLOCK (RUN POWER)
 - LOS - LOW OIL PRESSURE SWITCH
 - SM - STARTER MOTOR
 - WLS - COOLANT LEVEL SWITCH

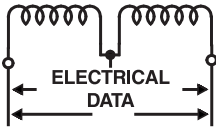

Section 6 - Electrical Data

QUIETSOURCE™ Liquid-cooled 30 kW Generators Electrical Schematic – Engine – Drawing No. 0E6200-B

LEGEND:

- AR - ALTERNATOR ROTOR
- AS - ALTERNATOR STATOR
- AVR - AUTOMATIC VOLTAGE REGULATOR
- BA - BRUSH ASSEMBLY (GENERATOR)
- B/C - BATTERY CHARGER
- BCW - BATTERY CHARGE WINDING
- CB1 - CIRCUIT BREAKER (OUTPUT)
- CB2 - CIRCUIT BREAKER (EXCITATION)
- D1 - DIODE [FIELD BOOST]
- DPE - DISPLACED PHASE EXCITATION

LEGEND (CONT.):

- F1 - FUSE, BAT. POWER (15A AGC TYPE)
- F2 - FUSE, B/C (4A AGC TYPE)
- ICT - TERMINAL BLOCK, INTERCONNECT.
- NB - NEUTRAL BLOCK
- RL1 - RELAY 1
- SW1 - SWITCH, AUTO/OFF/MANUAL
- SW2 - SWITCH, SET EXERCISER
- TR1 - TRANSFORMER 1 (56 VA 240/16 VAC)
- TR2 - TRANSFORMER 2 (6 VA 240/16 VAC)

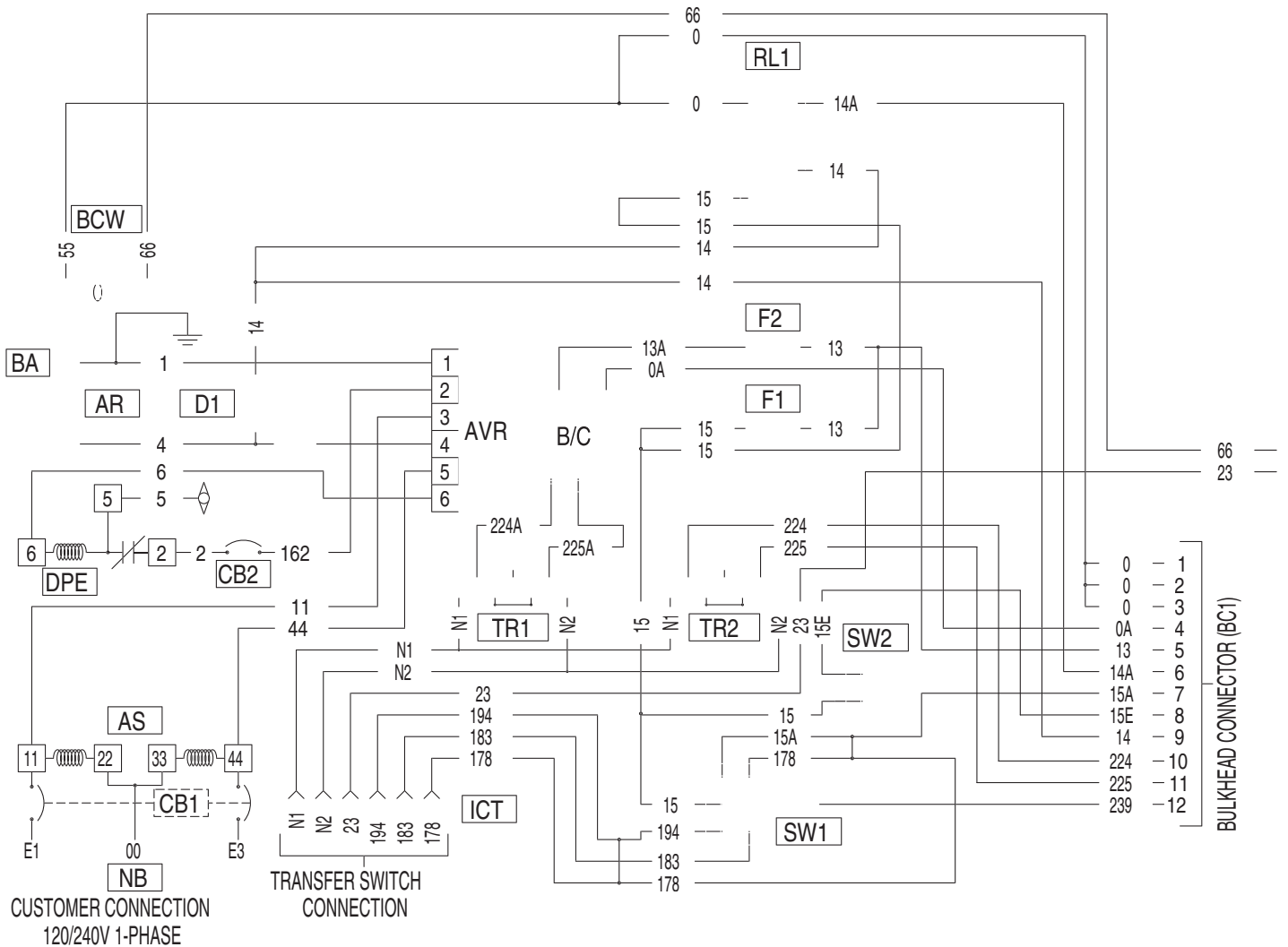

Section 6 - Electrical Data

QUIETSOURCE™ Liquid-cooled 30 kW Generators
Electrical Schematic – Engine – Drawing No. 0E6200-B

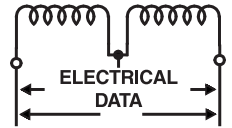

0 _____
 0 _____
 86 _____
 85 _____
 14 FS 0 _____
 _____ 56 CC 0 _____
 13 _____ 16 _____
 _____ 13 _____
 _____ ALT _____
 _____ SC _____
 _____ CM _____

12V BATTERY
 RED (+) (-) BLACK

PCB
 56 J1-1
 86 J1-2
 15A J1-3
 23 J1-4
 224 J1-5
 0 J1-6
 _____ J1-7 J2-1
 239 J1-8 J2-2
 _____ J1-9 J2-3
 15E J1-10
 85 J1-11
 14A J1-12
 225 J1-13
 66 J1-14

66
23

1	0
2	0
3	0
4	0A
5	13
6	14A
7	15A
8	15E
9	14
10	224
11	239
12	66

CONNECTOR (C1)

TO

2

9

4

5

6

7



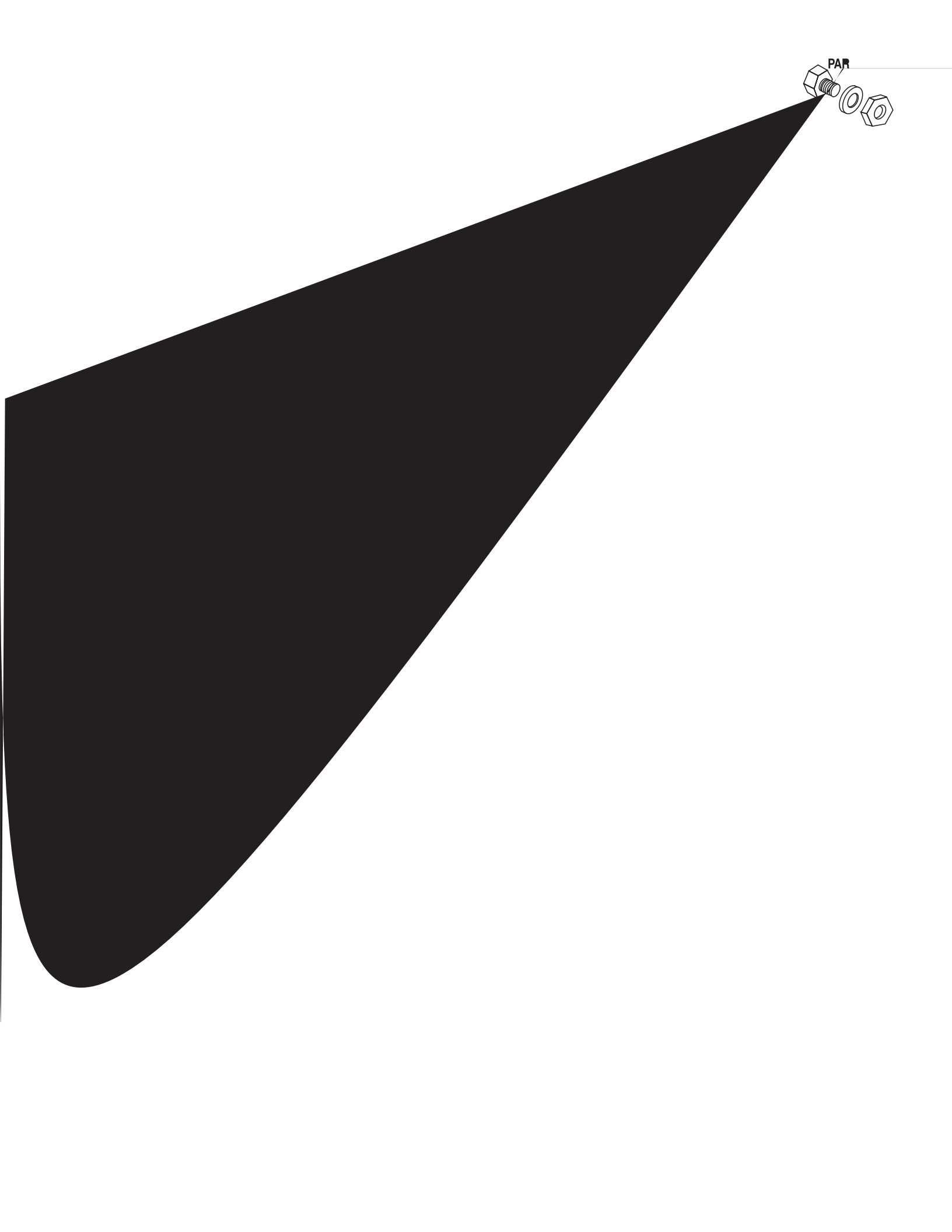
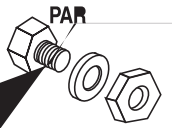

Section 7 - Exploded Views and Parts
QUIETSOURCE™ Liquid-cooled 30 kW Generators
 Compartment – Drawing No. 0F1141-A

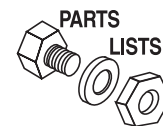

ITEM	PART NO.	QTY.	DESCRIPTION
1	0E8418	1	DUCT INTAKE MID AL
2	0E8414	1	DUCT DISCHARGE RH AL
3	0E8413	1	DUCT DISCHARGE LH AL
4	0C2454	62	SCREW TH-FRM M6-1 X 16 N WA Z/JS
5	0E8402	1	BAFFLE REAR BOTTOM
6	0E5902	1	POST CORNER LH REAR HSB AL
7	0E5903	1	POST CORNER RH REAR HSB AL
8	0E8387	1	BAFFLE REAR TOP
9	0E5912	2	DOOR SIDE HSB AL
10	0F5570	1	SUPPORT RH SIDE HSB AL
11	089961	2	FOAM STRIP 3/4" WIDE X 3/16" THK (40" LG)
12	0A2115	4	WASHER NYLON .257
13	0E8404	1	BRACKET STIFFENER RH FRONT
14	0F0165A	1	HINGE TYPE B W/STUDS, SOCKET
15	0F0165	1	HINGE TYPE B W/STUDS, PIN
16	0E7829S	1	AI SUPPORT LH PANEL
17	022097	12	WASHER LOCK M6-1/4
18	022473	12	WASHER FLAT 1/4-M6 ZINC
19	0E7570	2	GAS SPRING
20	0E7571	4	BALL STUD GAS SPRING MOUNT
21	070015	4	NUT HEX 5/16-18 LOCK
22	0E7662	4	SCREW WING M6-1.00 X 25
23	0F0164A	1	HINGE TYPE A W/STUDS, SOCKET
24	0F0164	1	HINGE TYPE A W/STUDS, PIN
25	0D2023	3	GASKET CLIP-ON SELF GRIPPING (84" LG)
26	0E7869	2	BRACKET STIFFENING BACK
27	0E8001	1	MUFFLER BOX
28	0F5568	1	ROOF HSB AL ACOUSTIC
29	0E5915	1	BRACE FRONT TOP HSB AL
30	0D3037A	1	LATCH 1/4 TURN NONLOCKING
31	0C7781	2	PAWL DOOR HSB
32	0E5910	1	SUPPORT LH SIDE HSB AL
33	0E8052	1	MUFFLER BOX TOP
34	0D3037	1	LATCH QUARTER TURN LOCKING
35	0E5900	1	POST CORNER LH FRONT HSB AL
36	0E5901	1	POST CORNER RH FRONT HSB AL
37	0F1131	1	BRACE, FRONT BOT 3.0L FD ALUM
38	0E8415	1	DUCT DISCHARGE MID AL
39	026850	4	WASHER SHAKEPROOF EXT 1/4 STL
40	0912970063	2	ASSY GRD WIRE 99HSB
41	0912970064	2	ASSEMBLY,BASE-DOOR GROUND WIRE
42	049813	10	NUT HEX M6 X 1.0 G8 YEL CHR
43	0E8416	1	DUCT INTAKE LH AL
44	0E8417	1	DUCT INTAKE RH AL
45	0E8665	1	BRACKET STIFFENER LH FRONT
46	078115	8	WASHER SELF LOCKING DOME
47	0E7829U	2	AI BRACE PANEL
48	0E7829N	2	AI ROOF PANEL 2
49	0E7829T	1	AI SUPPORT RH PANEL
50 *	0E8441	1	KIT INSULATION 3.0L HSB
51	0E7829A	1	AI ROOF PANEL 1
52	0E7829B	2	AI DOOR PANEL
53	0E7829P	4	AI CORNER POST PANEL 1
54	0E7829R	2	AI CORNER POST PANEL 2

* ALL ITEMS NOTATED WITH "AI" ARE COMPONENTS OF 0E8441

Section 7 - Exploded Views and Parts

**QUIETSOURCE™ Liquid-cooled 30 kW Generators
Control Panel – Drawing No. 0E7118-J**

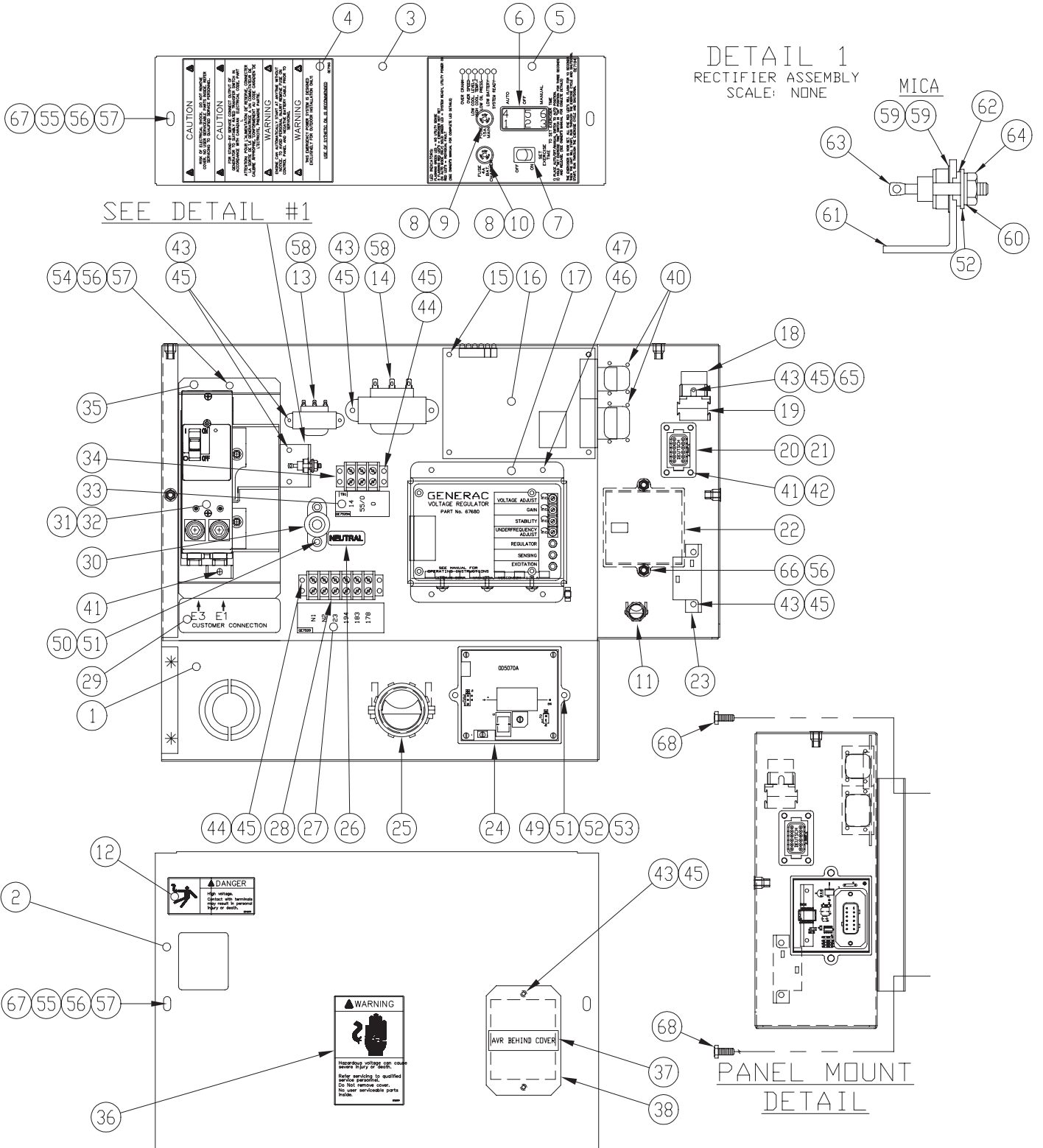

Section 7 - Exploded Views and Parts

QUIETSOURCE™ Liquid-cooled 30 kW Generators
Control Panel – Drawing No. 0E7118-J

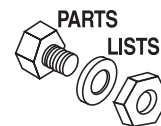

ITEM	PART NO.	QTY.	DESCRIPTION	ITEM	PART NO.	QTY.	DESCRIPTION
1	0E7195	1	CONTROL BOX HSB	36	0C1229	1	DECAL WARNING ELECTRICAL SHOCK
2	0E7196	1	COVER FRONT PANEL HSB	37	0C1127	1	DECAL AVR COVER
3	0E7197	1	COVER TOP PANEL HSB	38	0A1441B	1	COVER PLATE, AVR
4	0E7193	1	DECAL WARNINGS HSB	39	0E7128	1	HARNESS CNTRL PNL (NOT SHOWN)
5	0E7194	1	DECAL CONTROLS HSB	40	0E7358	8	SCREW PPPH HI-LO #4-24 X 3/8
6	0E4494	1	SWITCH ROC DPDT ON-OFF-ON	41	074908	6	SCREW HHTT M5-0.8 X 10 BP
7	082573	1	SWITCH ROCKER DPST 125V SPD	42	0C5141	1	CONN DEUTSCH GASKET 8/12 POS DT
8	032300	2	HOLDER FUSE	43	0C2699	11	SCREW PHTT #6-32 X 3/8 ZYC
9	022676	1	FUSE 15A X AGC15	44	0C2323	4	SCREW PHTT #6-32 X 5/8 ZYC
10	067682B	1	FUSE 4A SLO BLO GLASS	45	022155	15	WASHER LOCK #6
11	060015	1	FITTING CONDUIT 90D 3/8"	46	0C2265	4	SCREW PHTT M4-0.7 X 12 ZYC
12	054199	1	DECAL DANGER HIGH VOLTAGE	47	022264	4	WASHER LOCK #8-M4
13	0C2657	1	TRANSFRMR 16V 6VA	49	020911	2	SCREW PPHM M5-0.8 X 30 ZINC
14	099076	1	TRANSFORMER 16V 56VA	50	066849	2	SCREW HHTT M5-0.8 X 16
15	040213	2	PCB SUPPORT SNAP-IN 1/4"	51	022152	4	WASHER LOCK #10
16	0E9668	1	ASSY PCB HSB CONTROLLER 3.9L	52	023897	3	WASHER FLAT #10 ZINC
	0E4905	1	ASSY PCB HSB CONTRLR 3.0L FORD	53	051716	2	NUT HEX M5-0.8 G8 YEL CHR
17	067680	1	ASSY VOLTAGE REGULATOR 60HZ	54	090388	2	SCREW HHTT M6-1.0 X 12 ZINC
18	0E6875A	1	RELAY 12VDC C FORM W/DIODE	55	042568	4	SCREW HHC M6-1.0 X 20 G8.8
19	0E6881 *	REF.	SOCKET RELAY	56	022097	8	WASHER LOCK M6-1/4
20	0C5139 *	REF.	CONN DEUTSCH RECEPT GY/FLN	57	022473	6	WASHER FLAT 1/4-M6 ZINC
21	0C5142 *	REF.	CONN DEUTSCH RECEPT WDGE BLKHD	58	0441140187	2	WIRE ASSY 3" X (2) 3/16" TABS
22	0E3161	1	ASSY BOSCH GOV DRIVER	59	070370	2	WASHER MICA .203
23	054450	1	CIRCT BRK 5.5 X 1 ETA 46-500-P	60	023762	1	WASHER SHAKEPROOF EXT #10 STL
24	0D5070A	1	ASSY 2A 12V UL BATTERY CHARGER	61	055444	1	HEATSINK
25	0E2514	1	FITTING CONDUIT STR 1-1/2"	62	030468	1	WASHER STEP NYLON .20
26	0A9457	1	DECAL NEUTRAL	63	049939	1	RECTIFIER MSC 12A 600V 1N1206R
27	0E7539	1	DECALCUSTOMER CNNCTN XFER SW	64	022158	1	NUT HEX #10-32 STEEL
28	046357 *	REF.	BLOCK TERM 20A 6 X 6 X 1100V	65	022985	1	WASHER FLAT #6 ZINC
29	0D3719B	1	DECAL CUSTOMER CNNCTN	66	038750	2	SCREW HHC M6-1.0 X 30 G8.8
30	057073	1	JUNCTION BLOCK 3/8-16	67	0A2115	4	WASHER NYLON .257
31	0E7283	1	CB 0150A2P240V S QN2 LL	68	0C2454	4	SCREW THF M6-1 X 16 N WA Z/JS
	0E3628	1	CB 0200A2P240V S QN2 LL	69	0F6146	1	HANG TAG 2 WIRE START (NOT SHOWN)
32	0E3664	1	BASE QN CIRCUIT BREAKER				
33	0E7539A	1	DECAL TB1 HSB CONTROL PANEL				
34	0D4698 *	REF.	BLOCK TERM 20A 6 X 3 X 1100V				
35	0E7252	1	BRACKET CB 221.5 X 102				

* ITEMS INCLUDED AS PART OF I/N 39

PARTS
LISTS

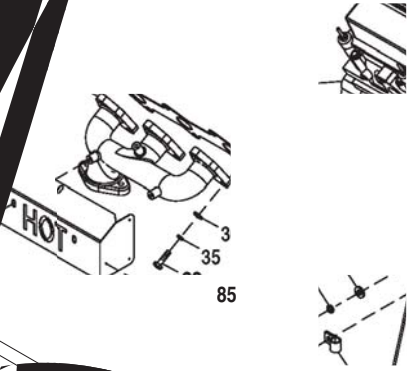

11

72

74

81

80

79

Section 7 - Exploded Views and Parts
QUIETSOURCE™ Liquid-cooled 30 kW Generators
Engine — Drawing No. 0E8170-N

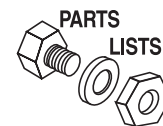

ITEM	PART NO.	QTY.	DESCRIPTION	ITEM	PART NO.	QTY.	DESCRIPTION
1	0E6202	1	ENGINE 3.0L FORD (RD) (MAKE)	47	049808	2	WASHER FLAT M12
2	0E8824	2	STAMPING ENG FOOT 3.0L FORD	48	051430	6	WASHER SHAKEPROOF INT 1/2
3	0E8963	1	PULLEY CRANKSHAFT 3.0L FORD RD	49	045773	3	NUT HEX M12-1.75 G8 YEL CHR
4	0E9020	1	BRACKET DC ALT 3.0L FORD	50	0E6203C	1	COIL IGNITION 3.0L FORD
5	0A1232	1	D.C. ALTERNATOR ASSY	51	0E6679	2	BRACKET IGN COIL 3.0L FORD
6	0A7801B	1	PULLEY POLY-V 82 OD.	53	049226	7	WASHER LOCK M5
7	0A5610	1	BRACKET ALTERNATOR	54	091526	3	SCREW PPHM M5-0.8 X 12 ZNC
8	0E6308	1	PULLEY WATERPUMP 3.0L FORD (RD)	55	093278	4	SCREW HHTT M5-0.8 X 25 BP
9 **	0E7804	1	HARN IGNITION 3.0L FORD (NOT SHOWN)	56	0E6517	1	HARNES ENGINE 3.0L FORD HSB (NOT SHOWN)
10	0D3488F	1	BELT SERPENTINE 38.35	57	0E7163	2	GASKET EXHAUST 3.0L FORD
11	0E7996	1	CLUTCH COOLING FAN FORD	58	0E5527	2	MANIFOLD EXHAUST 3.0L FORD
12	0E8006	1	FAN 18" 7 BLADE STEEL ECS	60	0E7202	2	HEAT SHIELD 260 X 80 HOT
14	035606	1	SENSOR HI COOLANT SHUTDOWN	61	085296	6	SCREW HHC 1/4-20 X 1/2 SS
15	0E0561	1	ASSY WATER LEVEL SENSOR C/E PL	62	0E6203D	1	WIRE SET 3.0L FORD (NOT SHOWN)
16	0E6729	1	STARTER DELCO-REMY 12V	63	057772	1	WASHER NYLON .565
17	0E6703	1	COVER FLYWHEEL ACCESS 3.0L HSB	64	057765	1	ADAPTER M14-1.50 X 3/8 NPT
18	0E6667	1	ENGINE ADAPTER 3L FORD	65	043790	1	BARBED EL 90 3/8 NPT X 3/8
19	0E5048	1	FLEXPLATE 3.0L FORD	66	069860C	1	HOSE OIL DRAIN ASSY 21"
20	035579	1	BUSHING REDUCER 1/4 TO 1/8	67	057822	2	CLAMP HOSE #8 .53-1.00
21	0A8584	1	SWITCH OIL PRESSURE 10PSI 2POL	68	069811	1	CAP HEX 1/4 NPT BRASS
24	083896	6	WASHER LOCK 1/4-M6 SS	69	026925	1	PLUG STD PIPE 3/8 STEEL SQ HD
25	084929	6	WASHER FLAT 1/4 SS	70 *	065852	1	SPRING CLIP HOLDER .37-.62
26	055597	1	SCREW HHC M12-1.75 X 85 G8.8	71 *	0A2111	1	SCREW SWAGE 10-32 X 5/16 Z/YC
27	077996	1	CAP HOSE	72	057073	1	JUNCTION BLOCK 3/8-16
28	057823	1	CLAMP HOSE #10 .56-1.06	73	066849	2	SCREW HHTT M5-0.8 X 16
29	056739	1	RELAY SOLENOID 12VDC PNL MNT	74	022152	2	WASHER LOCK #10
30	047411	6	SCREW HHC M6-1.0 X 16 G8.8	75	0E7880	2	CLIP SPARK PLUG 3P SCREW-MOUNT (NOT SHOWN)
31	022097	6	WASHER LOCK M6-1/4	76	0E7880A	4	CLIP SPARK PLUG 2P SCREW-MOUNT (NOT SHOWN)
32	022473	6	WASHER FLAT 1/4-M6 ZINC	77	0E7880B	1	CLIP SPARK PLUG 3P FREEHANG (NOT SHOWN)
33	047411	4	SCREW HHC M6-1.0 X 16 G8.8	78	055934C	1	CLAMP VINYL .5 X .406 Z
34	040976	4	SCREW SHC M8-1.25 X 20 G12.9	79	027482	1	WASHER SHAKEPROOF EXT 5/16 STL
35	022129	24	WASHER LOCK M8-5/16	80	0E8940	1	SPACER FLEXPLATE HSB
36	022145	22	WASHER FLAT 5/16-M8 ZINC	81	0A7387	2	SCREW HHC M10-1.5 X 40 G10.9
37	045771	1	NUT HEX M8-1.25 G8 YEL CHR	82	022097	4	WASHER LOCK M6-1/4
38	051756	6	SCREW HHC M10-1.5 X 20 G8.8	83	022473	4	WASHER FLAT 1/4-M6 ZINC
39	049821	16	SCREW SHC M8-1.25 X 30 G12.9	84	055934H	2	CLAMP VINYL .62 X .406 Z
40	059980	4	SCREW HHC M10-1.5 X 25 G10.9	85	0F5966	1	REFLECTIVE HEAT SHIELD 3.0L FD
41	0D5417	REF.	SCREW HHC M10-1.0 X 25 G10.9	86	022985	3	WASHER FLAT #6 ZINC
42	046526	18	WASHER LOCK M10	87	036261	3	RIVET POP .125 X .275 SS
43	022131	11	WASHER FLAT 3/8-M10 ZINC				
44	059982	4	SCREW SHC M12-1.75 X 45 G10.9				
45	098780	2	SCREW HHC M12-1.75 X 65 G8.8				
46	051769	3	WASHER LOCK M12				

* NOT SHOWN-USED TO HOLD OIL DRAIN ASSEMBLY.

** NOT SHOWN



Section 7 - Exploded Views and Parts
QUIETSOURCE™ Liquid-cooled 30 kW Generators
Radiator – Drawing No. 0E8528-B

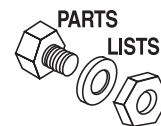

ITEM	PART NO.	QTY.	DESCRIPTION
1	0E9947	1	RADIATOR R-IN,L-OUT 658X489X49
2	0E6340	1	VENTURI 3.0L FORD HSB
3	0E8531	2	SIDE SUPPORT RADIATOR HSB
4	0E6398	1	TUBE LOWER RAD 3.0L FORD HSB
5	0E6397	1	HOSE UPPER RAD 3.0LFORD HSB
6	080713	1	BRACKET COOLANT TANK
7	076749	1	TANK COOLANT RECOVERY
8	049814	4	SCREW HHC M10-1.5 X 25 G8.8
9	022131	8	WASHER FLAT 3/8-M10 ZINC
10	046526	4	WASHER LOCK M10
11	045772	4	NUT HEX M10-1.5 G8 YEL CHR
12	035685	4	CLAMP HOSE #28 1.32-2.25
13	0E8562	1	FAN GUARD HSB
14	058443	4	SCREW CRIMPTITE 1/4-20 X 5/8
15	0C2454	9	SCREW TH-FRM M6-1 X 16 N WA Z/JS
17	048031C	1	CLAMP HOSE BAND 1/4
18	029032	1	HOSE 9/32 ID (30" LG)
20	046627	1	CAP RADIATOR
21	069811	1	CAP HEX 1/4 NPT BRASS
22	065852	1	SPRING CLIP HOLDER .37-.62
23	0A2111	1	SCREW SWAGE 10-32 X 5/16 Z/YC
24	052250	2	TAPE FOAM 1 X 1 (27" LG)
25	035461	1	BARBED STR 1/4 NPT X 3/8
26	0C7649	1	CLAMP HOSE .38-.87
27	069860C	1	HOSE OIL DRAIN ASSY 21"

PARTS
LISTS

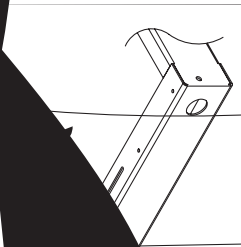
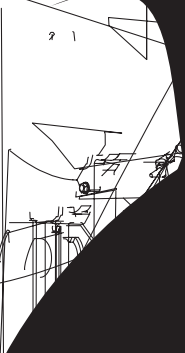
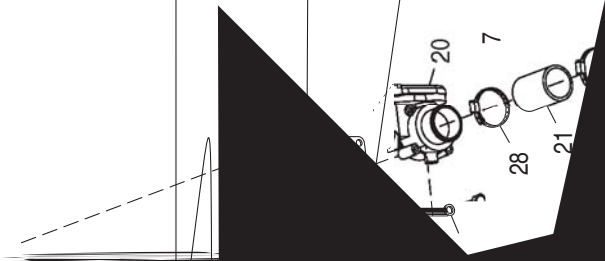

Section 7 - Exploded Views and Parts
QUIETSOURCE™ Liquid-cooled 30 kW Generators
Fuel System – Drawing No. 0E8190-C

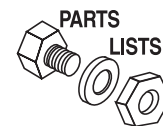

ITEM	PART NO.	QTY.	DESCRIPTION
1 *	-----	1	WELDMENT MOUNTING BASE
2	075580	1	FLANGE FUEL INLET
3	0E7691	1	ASSY REGULATOR 3.0L NG OR LPV
4	039253	2	SCREW HHC M8-1.25 X 20 G8.8
5	022145	2	WASHER FLAT 5/16 ZINC
6	022129	4	WASHER LOCK M8-5/16
7	045771	2	NUT HEX M8-1.25 G8 YEL CHR
8	042907	2	SCREW HHC M8-1.25 X 16 G8.8
9	0C2454	2	SCREW TH-FRM M6-1 X 16 N WA Z/JS
10	026307	1	ELBOW 90D STREET 3/4
11	0E1056	1	FUEL HOSE ASSY NAT.GAS/L.P.V.
12	0E6584	1	BRACKET REGULATOR 3.0L FORD HSB
13	057823	2	CLAMP HOSE #10 .56 - 1.06
14	059194	1	HOSE 5/8 ID LPG & NG (20" LG)
15	044117	1	BARBED STR 3/8 NPT X 5/8
16	0D1509	1	DECAL INLET PRESSURE
17	050279	1	DECAL FUEL INLET NG
18	0E6123	1	INTAKE ADAPTER 3.0L FORD-BOSCH
19	0E6586	1	GASKET BOSCH 32
20	0E4395	1	ACTUATOR BOSCH 32 GOVERNOR
21	057753B	1	HOSE 1.5 ID X 2 LG 20R4
25	047487	4	SCREW SHC M6-1.0 X 18 G12.9
26	022097	8	WASHER LOCK M6-1/4
27	051751	4	SCREW HHC M6-1.0 X 50 G8.8
28	035685	2	CLAMP HOSE #28 1.32-2.25
29	057823	4	CLAMP HOSE #10 .56-1.06
30	047290	1	HOSE 3/8 ID SINGLE BRAID (305mm [12"] LONG)
31	047290	1	HOSE 3/8 ID SINGLE BRAID (432mm [17"] LONG)
32	0A4121	1	VALVE PCV
33	0E6609	1	GROMMET ROCKER COVER 3.0LFORD
34	049099	1	BARBED EL 90 3/8 X 3/8 PLST
35 **	055934M	1	CLAMP VINYL .75 X .343 Z
36 **	047411	1	SCREW HHC M6-1.0 X 16 G8.8
37 **	022097	1	WASHER LOCK M6-1/4
38 **	022473	1	WASHER FLAT 1/4-M6 ZINC
39	0E9295A	1	ASSY THROTTLE 27MM
40	0E6382A	1	VENTURI HOLDER W/32MM ACTUATOR
41	0E7121	1	O-RING 47.625 ID X 2.38 WIDTH
42	0E6376A	1	VENTURI, 27 ID THROTTLE W/CHOK
43	0F2119	1	O-RING 45.63 ID X 2.62 WIDTH

* SHOWN IN OTHER VIEW

** NOT SHOWN-USED TO HOLD #31 IN PLACE



Section 7 - Exploded Views and Parts
QUIETSOURCE™ Liquid-cooled 30 kW Generators
Alternator – Drawing No. 0F5092-A

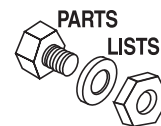

ITEM	PART NO.	QTY.	DESCRIPTION
1	0F1659A	1	ROTOR 390 15KW 1P DIRECT HSB (2.5L FORD)
	0F1657A	1	ROTOR 390 20KW 1P DIRECT HSB (2.5L FORD)
	0F1655A	1	ROTOR 390 25KW 1P DIRECT HSB (2.5L FORD)
	0F5073A	1	ROTOR 390__30AD1 HSB TECUM
	0E7413A	1	RTR 390 40KW 1P DIRECT HSB
2	0F1660A	1	STR 390 15AD HSB (382MM LONG) (2.5L FORD)
	0F1658A	1	STR 390 20AD HSB (382MM LONG) (2.5L FORD)
	0F1656A	1	STR 390 25AD HSB (382MM LONG) (2.5L FORD)
	0F5074A	1	STR-390__30AD1 HSB TECUM
	0E7412A	1	STR-390--40AD HSB (433MM LONG)
3	0E5706	1	REAR BEARING CARRIER 390/DRCT
4	0E5048	REF	FLEXPLATE 3.0L FORD
	0E5048B	REF	FLEXPLATE 2.5L FORD
	0E5048A	REF	FLEXPLATE HSB 3.9L CHRYSLER
5	0E6668	1	FLYWHEEL ASSY 3.0L HSB LG GEAR
6	0E6076	1	REVCOR FAN 10.75 X 2 W/PRESS DIS
7	046526	8	WASHER LOCK M10
8	051755	4	SCREW HHC M10-1.5 X 16 G8.8
9	04576100BK	4	STUD M14-2.0 X 490 G5 ZINC (3.0L FORD & 2.5L FORD)
	04576100BF	4	STUD M14-2.0 X 540 G5 ZINC
10	043123	4	WASHER LOCK M14
11	051779	4	NUT HEX M14-2.0 G8 YEL CHR
12	0E7587	1	ASSY BRUSH HOLDER 390/HSB
13	023365	1	WASHER SHAKEPROOF INT #8
14	0C3993	4	SCREW HHTT M4-0.7 X 25 BP
15	057192	4	SCREW SHC M10-1.5 X 30 G12.9
16	0A2602	1	WASHER FLAT .688 ID X 3.25 OD
17	042558	1	KEY SQ 3/8 X 1 STEEL
18	0A2601	1	SCREW HHC M16-2.0 X 45 G8.8
19	022264	4	WASHER LOCK #8-M4
20	038150	4	WASHER FLAT #8 ZINC
21	077043F	1	CONDUIT FLEX 1-1/4" (30" LG - 3.0L FORD & 3.9L CHRYSLER)
	077043F	1	CONDUIT FLEX 1-1/4" (18" LG - 2.5L FORD)
ROTOR REPLACEMENT PARTS			
30	047248	1	BALL BEARING-45 MM
31	070892	1	SLIP RING -MACHINED-

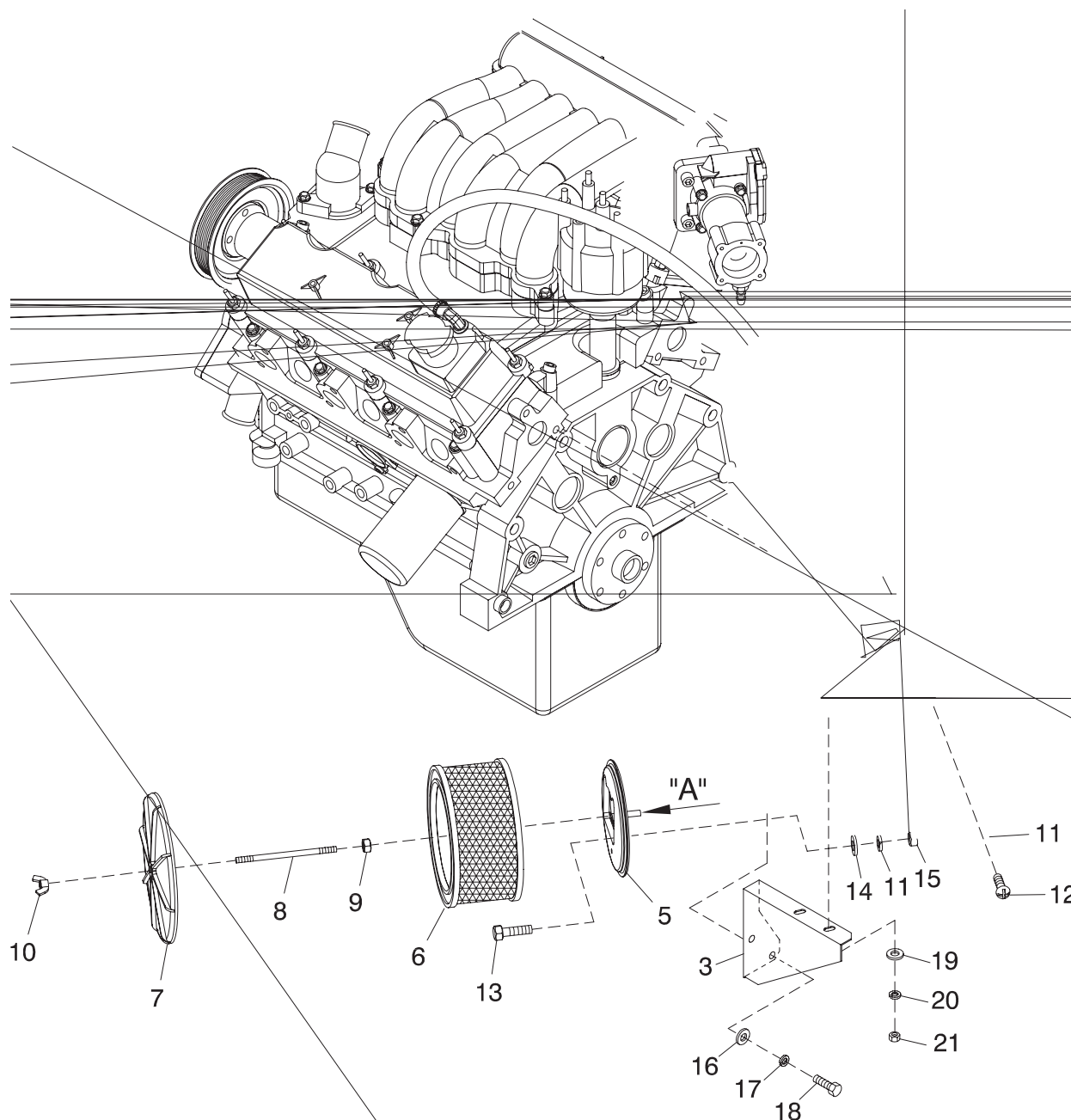

ITEM	PART NO.	QTY.	DESCRIPTION	ITEM	PART NO.	QTY.	DESCRIPTION
1	0E5193	1	PLATE AIR CLEANER ADAPTER	11	049226	8	WASHER LOCK M5
2	0E8200	1	TUBE AIR INTAKE 3.0L FORD	12	049815	4	SCREW HHC M5-0.8 X 16 G8.8
3	0E8201	1	BRACKET AIR INTAKE 3.0L FORD	13	052619	4	SCREW HHC M5-0.8 X 20 G8.8
4	036434	1	BOLT U 5/16-18 X 2.09	14	051713	4	WASHER FLAT M5
5	0E0519A	1	ADAPTER CARBURETOR W/PVC CONN	15	051716	4	NUT HEX M5-0.8 G8 YEL CHR
6	0C8127	1	ELEMENT AIR CLEANER	16	022131	2	WASHER FLAT 3/8-M10
7	0A5547	1	COVER - AIR CLEANER	17	046526	2	WASHER FLAT M10
8	062974	1	STUD TH 1/4-20 X 4-1/2 G2 ZNC	18	051755	2	SCREW HHC M10-1.5 X 16 G8.8
9	022127	1	NUT HEX 1/4-20 STEEL	19	022145	2	WASHER FLAT 5/16-M8 ZINC
10	037561	1	NUT WING 1/4-20 NYLK	20	022129	2	WASHER LOCK M8-5/16
				21	022259	2	NUT HEX 5/16-18 STEEL

